



POWERING

SUSTAINABLE SOLUTIONS



GENERAL INFORMATION

1. **STANDARDS**
2. **EFFICIENCY**
 - 2.1. *IEC 60034-30-1:2014*
 - 2.2. *IEC 60034-2-1:2014*
3. **DUTY TYPES**
4. **DEGREES OF PROTECTION**
5. **COOLING METHOD**
6. **TYPES OF CONSTRUCTION**
7. **LIMITS OF VIBRATION SEVERITY**
8. **INSULATION SYSTEM**
9. **VARIABLE SPEED DRIVES**
 - 9.1. *WINDING INSULATION*
 - 9.2. *COOLING*
 - 9.3. *BEARING LIFE - LUBRICATION*
 - 9.4. *MECHANICAL SPEED LIMITS*
 - 9.5. *BEARING CURRENTS*
10. **TOLERANCES**
11. **MECHANICAL DESIGN**
 - 11.1. **FRAME, ENDSHIELDS AND FLANGES**
 - 11.1.1. *ALUMINIUM FRAME*
 - 11.1.2. *CAST IRON FRAME*
 - 11.2. **LIFTING LUGS**
 - 11.3. **EXTERNAL FINISH**
 - 11.4. **SHAFT EXTENSION**
 - 11.5. **VIBRATION MEASURE POINTS AND NIPPLES**
 - 11.6. **DRAIN HOLES**
 - 11.7. **ANTI-CONDENSATION HEATING ELEMENTS**
 - 11.8. **COOLING**
 - 11.9. **CABLE GLAND**
 - 11.10. **TERMINAL BOX**
 - 11.11. **BEARINGS**
 - 11.11.1. *BEARING LIFETIME AND LUBRICATION*
 - 11.11.2. *PERMISSIBLE RADIAL FORCES*
 - 11.11.3. *PERMISSIBLE AXIAL FORCES*
 - 11.12. **MOTOR PROTECTION**
 - 11.12.1. *PTC*
 - 11.12.2. *PT100*
 - 11.12.3. *BIMETAL THERMAL PROTECTORS*
 - 11.13. **VOLTAGE AND FREQUENCY**
 - 11.14. **PRODUCT CODE**
 - 11.15. **NAME PLATE**

TECHNICAL DATA

PERFORMANCE VALUES

IE3 ALUMINIUM and CAST IRON; 2, 4, 6 AND 8 POLE MOTORS

IE4 ALUMINIUM and CAST IRON; 2, 4 AND 6 POLE MOTORS

DEMAND CODES

DIMENSION DRAWINGS

B3, B5, B14, B35 and B34; ALUMINIUM MOTORS

B3, B5, B14, B35 and B34; CAST IRON MOTORS

MOTORS IN BRIEF

IE3 and IE4, 71 - 112 ALUMINIUM MOTORS

COMPONENTS

71 - 112 ALUMINIUM MOTORS

MOTORS IN BRIEF

IE3 and IE4, 132 - 250 ALUMINIUM MOTORS

COMPONENTS

132 - 250 ALUMINIUM MOTORS

MOTORS IN BRIEF

IE3 and IE4, 160 - 400 CAST IRON MOTORS

COMPONENTS

160 - 400 CAST IRON MOTORS

3
4
7
9
9
10
11
11
12
14
16
16
16
18
18
18
19
19
20
20
21
22
30
31
32
33

34
52
54
60
61
62
63
64
65

Omega Motor Product Journey



Stator lamination steel sheet

Stator core

Aluminium injected rotor

Rotor lamination steel sheet

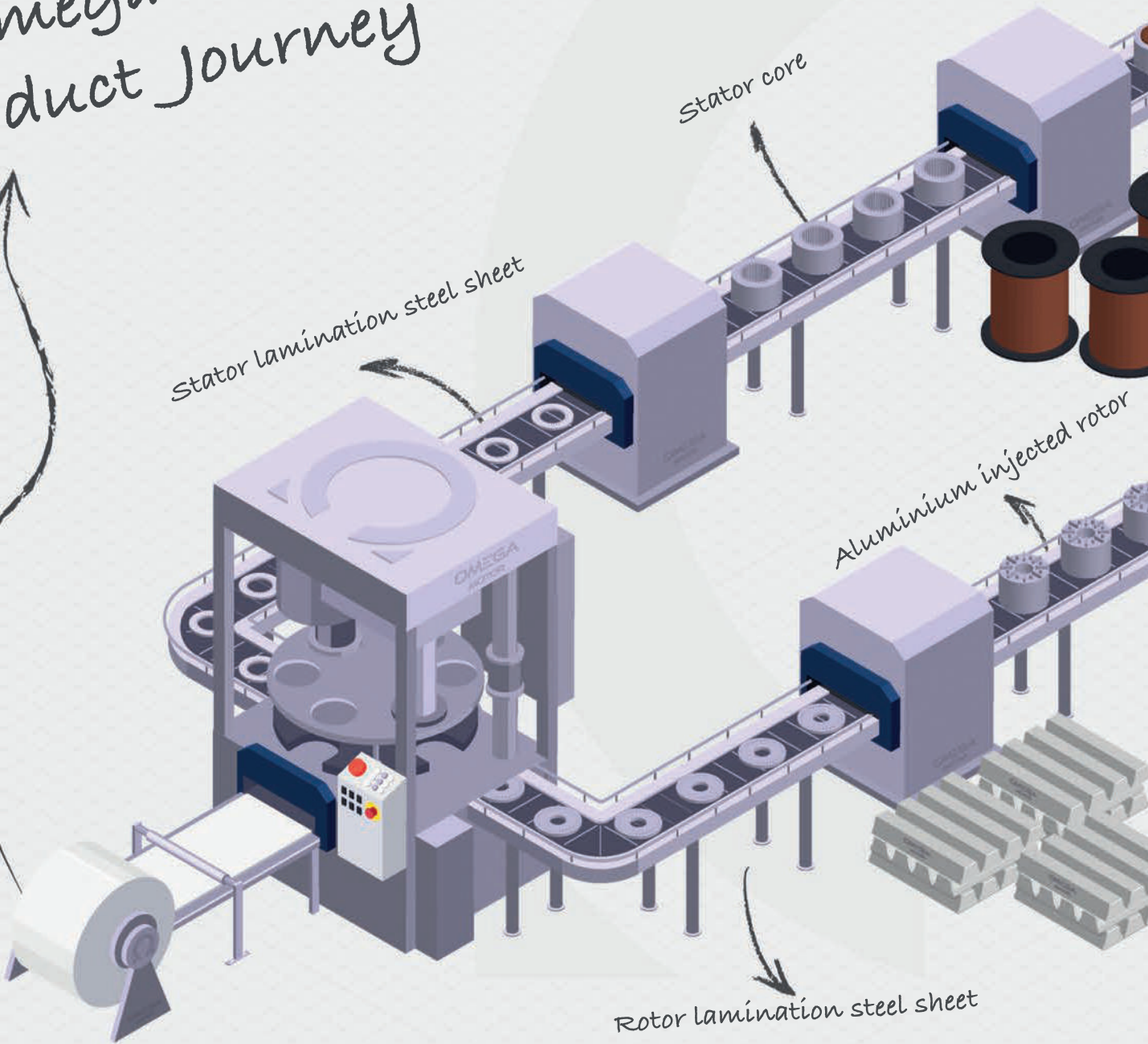

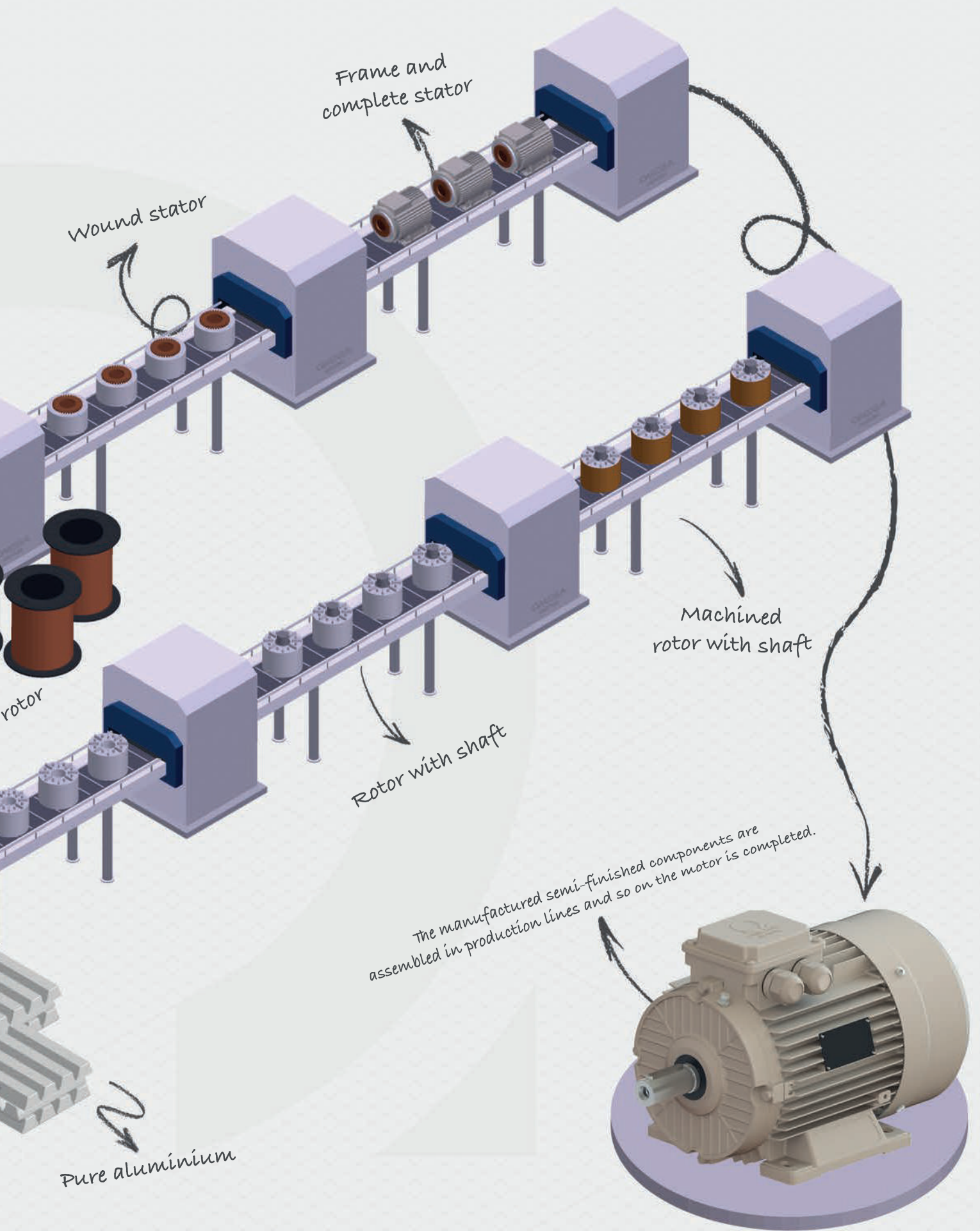

1. STANDARDS

Omega Motor low voltage induction motors are designed, produced and tested in accordance with the given international electrical and mechanical standards.

TITLE	IEC
Rating and performance	IEC 60034-1
Standard methods for determining losses and efficiency from tests	IEC 60034-2-1
Degrees of protection provided by the integral design of rotating electrical machines (IP Code)	IEC 60034-5
Methods of cooling (IC Code)	IEC 60034-6
Classification of types of construction, mounting arrangements and terminal box position (IM Code)	IEC 60034-7
Terminal markings and direction of rotation	IEC 60034-8
Noise limits	IEC 60034-9
Thermal protection	IEC 60034-11
Starting performance of single-speed three-phase cage induction motors	IEC 60034-12
Measurement, evaluation and limits of vibration severity	IEC 60034-14
Effects of unbalanced voltages on the performance of three-phase cage induction motors	IEC 60034-26
Efficiency classes of line operated AC motors (IE Code)	IEC 60034-30-1
Selection of energy-efficient motors including variable speed applications - Application guide	IEC 60034-31
Standard voltages	IEC 60038
Dimensions and output series for rotating electrical machines - Frame numbers 56 to 400 and flange numbers 55 to 1080	IEC 60072-1
Dimensions and output series for rotating electrical machines - Frame numbers 355 to 1000 and flange numbers 1180 to 2360	IEC 60072-2
Electrical insulation - Thermal evaluation and designation	IEC 60085
Control units for built-in thermal protection (PTC) for rotating electrical machines	IEC 60947-8
Test code for the measurement of airborne noise emitted by rotating electrical machines	EN ISO 1680

2. EFFICIENCY

In 1998 the European Committee of Manufacturers of Electrical Machines and Power Systems (CEMEP) issued a voluntary agreement of motor manufacturers on efficiency classification with three efficiency classes namely Eff1, Eff2, and Eff3, which can be treated as the first concrete approach towards efficiency in the European region. The lack of regularity authority behind the agreement have limited the success of this formation and helped to convert as low as 1% of Eff3 low-efficiency motors to Eff1 high-efficiency motors in about 10 years.

International Electrotechnical Commission (IEC) conducted a comprehensive study within this period of time and came up with two efficiency standards of which latest versions are 60034-30-1:2014 where IE codes are defined and 60034-2-1:2014 where test methods are specified.

IEC is an organization that defines efficiencies, test procedures by publishing standards but it is not a body that is controlling the application of these standards. They are rather controlled via MEPS (Minimum Energy Performance Standards) which are made mandatory by government energy efficiency bodies in the relevant countries. In the European Union, Eu regulation 2019/1781 and the supplement 2021/341 is a force to regulate energy efficiency of industrial motors in the industrial environment. In Turkey, it is regulated by communiqué 31468 (SGM-2021/16) dated 28/04/2021 on ecodesign requirements for electric motors and the supplement 31526 (SGM-2021/23) dated 29/06/2021.

The aim of this legislative regulation in the European Union and Turkey is to establish the efficiency class requirements for 2, 4, 6 and 8 pole motors within the power range of 0.12kW to 1000kW, which are commonly utilized in industry, by mandating the use of more efficient motors on specified dates, the regulation seeks to reduce CO2 emissions globally. Transitions are defined on two dates according to motors sizes and characteristics.

As of July 1, 2021;

- The energy efficiency of three phase motors ranging from 0.75kW to 1000kW must meet at least IE3 efficiency class.
- The energy efficiency of three phase motors with 2, 4, 6 and 8 poles ranging from 0.12kW to 0.75kW must meet at least IE2 efficiency class.

As of July 1, 2023;

- The energy efficiency of three phase motors with 2, 4 and 6 poles ranging from 75kW to 200kW must meet at least IE4 efficiency class.
- The energy efficiency of single phase motors with a rated output equal to or above 0.12kW must meet at least IE2 efficiency class.

Timeline as per EU Regulation

The table below lists the scope of the international standard IEC 60034-30-1 and of Regulation 2019/1781 and the supplement 2021/341. Those specified in table are given in minimum efficiency class.

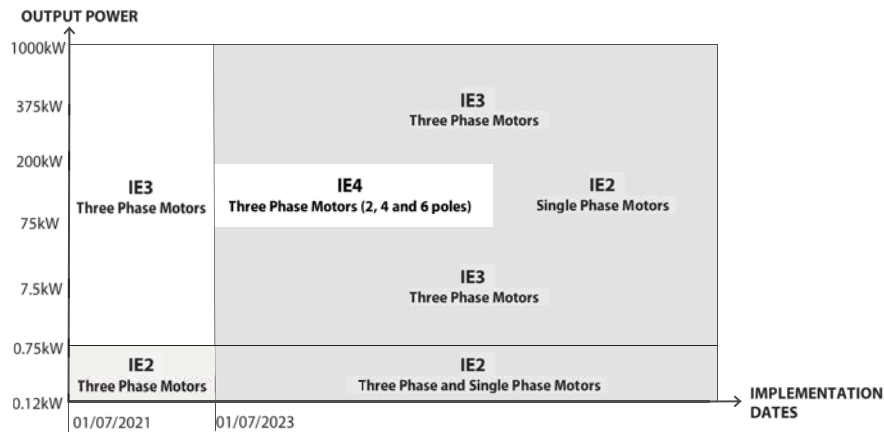

SCOPE	DIRECTIVES: 2019/1781 and 2021/341	STANDARD: IEC 60034-30-1:2014
Pole Number	2, 4, 6 and 8 pole	2, 4, 6 and 8 pole
Motor Output Power	0,12kW < P _N < 1000kW	0,12kW < P _N < 1000kW
Nominal Voltage	50V < U _N < 1000V	50V < U _N < 1000V
Frequency	50Hz, 60Hz or 50/60Hz	50Hz or 60Hz
Altitude	0 < altitude < 4000m	0 < altitude < 4000m
Ambient Temperature*	-30°C < t < 60°C	-20°C < t < 60°C
Maximum Operating Temperature	400°C	400°C**
Duty Type	S1, S3 ≥ %80 or S6 ≥ %80	All duty types suitable for continuous duty

* Minimum ambient temperature should be 0°C for water cooled motors.

** Smoke extraction motors

2.1. IEC 60034-30-1:2014

IEC 60034-30-1: 2014 specifies the latest efficiency classes for single-speed electric motors that are rated according to IEC 60034-1 and operating on a sinusoidal voltage supply.

The motors listed below are excluded from this standard:

- Single-speed motors with 10 or more poles or multi speed motors.
- Motors completely integrated into a machine (for example pump, fan and compressor) that cannot be tested separately from the driven machine.
- Motors with integrated frequency converter (compact drives) when the motor cannot be tested separately from the converter.
- Brake motors when the brake is an integral part of the inner motor construction and cannot be dismantled or separately fed.
- Submersible motors specially designed to operate wholly immersed in a liquid.

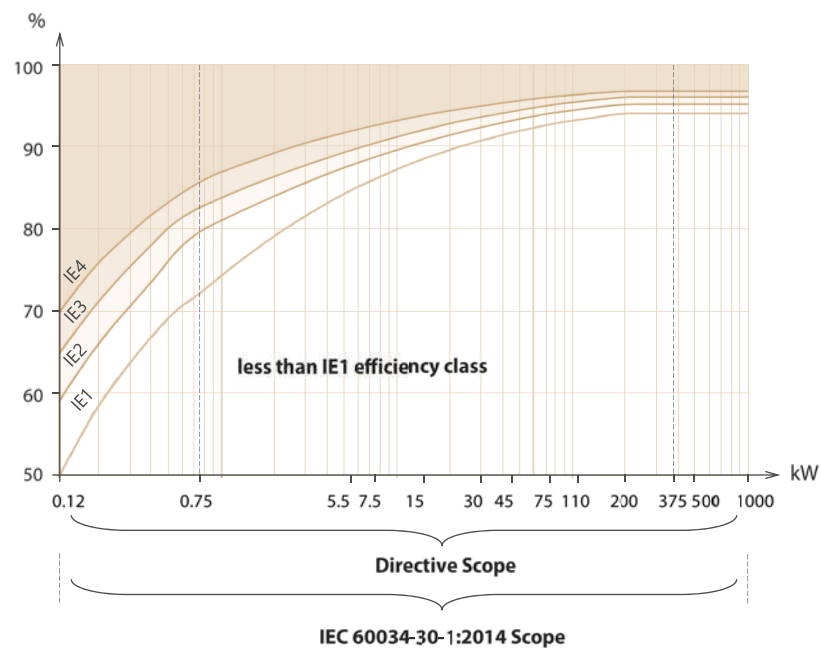

Efficiency levels for 4 pole motors (IEC 60034-30-1:2014)

2.2. IEC 60034-2-1:2014

IEC defines three different preferred testing methods in the latest IEC 60034-2-1:2014/06 standard, in order to determine the efficiencies of rotating electrical machines.

Omega Motor uses test **Method 2-1-1B** with low uncertainty. This is an indirect method and determines the efficiency by summation of losses with additional load losses from residual losses. The respective loss components are iron losses, windage and friction losses, stator and rotor losses and additional load losses. These losses are calculated by parameters measured and derived during the test of the motor, hence by their summation, the motor efficiency is determined precisely.

There are two other test methods in the standards which can be preferred depending on the type or rating of the machine undertest.

- **Method 2-1-1A:** Direct measurement of input and output
- **Method 2-1-1C:** Summation of losses with additional load losses from assigned allowance.

Nominal efficiency values (%) for 50Hz are specified in IEC 60034-30-1:2014 and given below:

Efficiency value determination based on the test methods specified in IEC 60034-2-1:2014

Output Power	IE1 Standard Efficiency Motors				IE2 High Efficiency Motors				IE3 Premium Efficiency Motors				IE4 Super Premium Efficiency Motors			
	2 pole	4 pole	6 pole	8 pole	2 pole	4 pole	6 pole	8 pole	2 pole	4 pole	6 pole	8 pole	2 pole	4 pole	6 pole	8 pole
0,12	45,0	50,0	38,3	31,0	53,6	59,1	50,6	39,8	60,8	64,8	57,7	50,7	66,5	69,8	64,9	62,3
0,18	52,8	57,0	45,5	38,0	60,4	64,7	56,6	45,9	65,9	69,9	63,9	58,7	70,8	74,7	70,1	67,2
0,20	54,6	58,5	47,6	39,7	61,9	65,9	58,2	47,4	67,2	71,1	65,4	60,6	71,9	75,8	71,4	68,4
0,25	58,2	61,5	52,1	43,4	64,8	68,5	61,6	50,6	69,7	73,5	68,6	64,1	74,3	77,9	74,1	70,8
0,37	63,9	66,0	59,7	49,7	69,5	72,7	67,6	56,1	73,8	77,3	73,5	69,3	78,1	81,1	78,0	74,3
0,40	64,9	66,8	61,1	50,9	70,4	73,5	68,8	57,2	74,6	78,0	74,4	70,1	78,9	81,7	78,7	74,9
0,55	69,0	70,0	65,8	56,1	74,1	77,1	73,1	61,7	77,8	80,8	77,2	73,0	81,5	83,9	80,9	77,0
0,75	72,1	72,1	70,0	61,2	77,4	79,6	75,9	66,2	80,7	82,5	78,9	75,0	83,5	85,7	82,7	78,4
1,1	75,0	75,0	72,9	66,5	79,6	81,4	78,1	70,8	82,7	84,1	81,0	77,7	85,2	87,2	84,5	80,8
1,5	77,2	77,2	75,2	70,2	81,3	82,8	79,8	74,1	84,2	85,3	82,5	79,7	86,5	88,2	85,9	82,6
2,2	79,7	79,7	77,7	74,2	83,2	84,3	81,8	77,6	85,9	86,7	84,3	81,9	88,0	89,5	87,4	84,5
3	81,5	81,5	79,7	77,0	84,6	85,5	83,3	80,0	87,1	87,7	85,6	83,5	89,1	90,4	88,6	85,9
4	83,1	83,1	81,4	79,2	85,8	86,6	84,6	81,9	88,1	88,6	86,8	84,8	90,0	91,1	89,5	87,1
5,5	84,7	84,7	83,1	81,4	87,0	87,7	86,0	83,8	89,2	89,6	88,0	86,2	90,9	91,9	90,5	88,3
7,5	86,0	86,0	84,7	83,1	88,1	88,7	87,2	85,3	90,1	90,4	89,1	87,3	91,7	92,6	91,3	89,3
11	87,6	87,6	86,4	85,0	89,4	89,8	88,7	86,9	91,2	91,4	90,3	88,6	92,6	93,3	92,3	90,4
15	88,7	88,7	87,7	86,2	90,3	90,6	89,7	88,0	91,9	92,1	91,2	89,6	93,3	93,9	92,9	91,2
18,5	89,3	89,3	88,6	86,9	90,9	91,2	90,4	88,6	92,4	92,6	91,7	90,1	93,7	94,2	93,4	91,7
22	89,9	89,9	89,2	87,4	91,3	91,6	90,9	89,1	92,7	93,0	92,2	90,6	94,0	94,5	93,7	92,1
30	90,7	90,7	90,2	88,3	92,0	92,3	91,7	89,8	93,3	93,6	92,9	91,3	94,5	94,9	94,2	92,7
37	91,2	91,2	90,8	88,8	92,5	92,7	92,2	90,3	93,7	93,9	93,3	91,8	94,8	95,2	94,5	93,1
45	91,7	91,7	91,4	89,2	92,9	93,1	92,7	90,7	94,0	94,2	93,7	92,2	95,0	95,4	94,8	93,4
55	92,1	92,1	91,9	89,7	93,2	93,5	93,1	91,0	94,3	94,6	94,1	92,5	95,3	95,7	95,1	93,7
75	92,7	92,7	92,6	90,3	93,8	94,0	93,7	91,6	94,7	95,0	94,6	93,1	95,6	96,0	95,4	94,2
90	93,0	93,0	92,9	90,7	94,1	94,2	94,0	91,9	95,0	95,2	94,9	93,4	95,8	96,1	95,6	94,4
110	93,3	93,3	93,3	91,1	94,3	94,5	94,3	92,3	95,2	95,4	95,1	93,7	96,0	96,3	95,8	94,7
132	93,5	93,5	93,5	91,5	94,6	94,7	94,6	92,6	95,4	95,6	95,4	94,0	96,2	96,4	96,0	94,9
160	93,8	93,8	93,8	91,9	94,8	94,9	94,8	93,0	95,6	95,8	95,6	94,3	96,3	96,6	96,2	95,1
200	94,0	94,0	94,0	92,5	95,0	95,1	95,0	93,5	95,8	96,0	95,8	94,6	96,5	96,7	96,3	95,4
250	94,0	94,0	94,0	92,5	95,0	95,1	95,0	93,5	95,8	96,0	95,8	94,6	96,5	96,7	96,5	95,4
315	94,0	94,0	94,0	92,5	95,0	95,1	95,0	93,5	95,8	96,0	95,8	94,6	96,5	96,7	96,6	95,4
355	94,0	94,0	94,0	92,5	95,0	95,1	95,0	93,5	95,8	96,0	95,8	94,6	96,5	96,7	96,6	95,4
400	94,0	94,0	94,0	92,5	95,0	95,1	95,0	93,5	95,8	96,0	95,8	94,6	96,5	96,7	96,6	95,4
450	94,0	94,0	94,0	92,5	95,0	95,1	95,0	93,5	95,8	96,0	95,8	94,6	96,5	96,7	96,6	95,4
500-1000	94,0	94,0	94,0	92,5	95,0	95,1	95,0	93,5	95,8	96,0	95,8	94,6	96,5	96,7	96,6	95,4

3. DUTY TYPES

The electrical losses and temperature variations over time in motors under different duty types contingent upon load and speed, are delineated in the IEC 60034-1 standard. The duty types specified in the standard are explained with graphics below.

The motors are manufactured in S1 duty type when no specific requests regarding duty types are made by the user.

S1: Continuous Duty

The motor operates at constant load until it reaches thermal equilibrium.

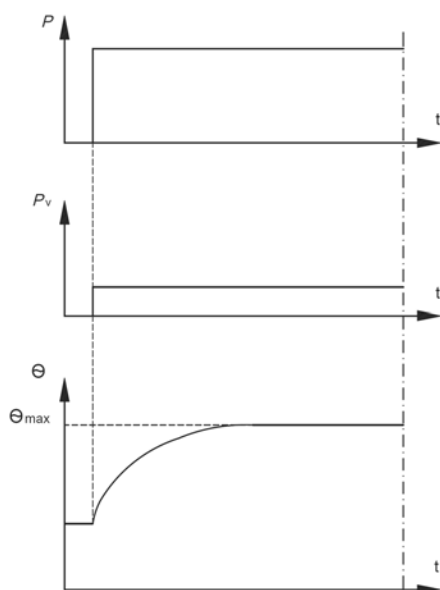

S2: Short Time Duty

The motor operates less time than required to reach thermal equilibrium at constant load and remains de-energized until the environment cools down.

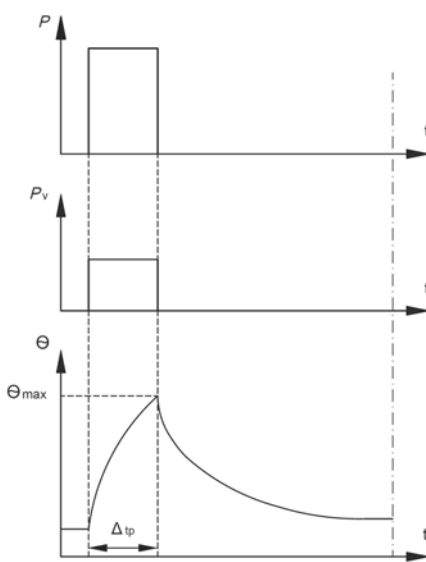

S3: Intermittent Periodic Duty

The motor operates periodically in two parts: a time of operation at constant load and at rest. The starting currents does not significantly affect the temperature rise.

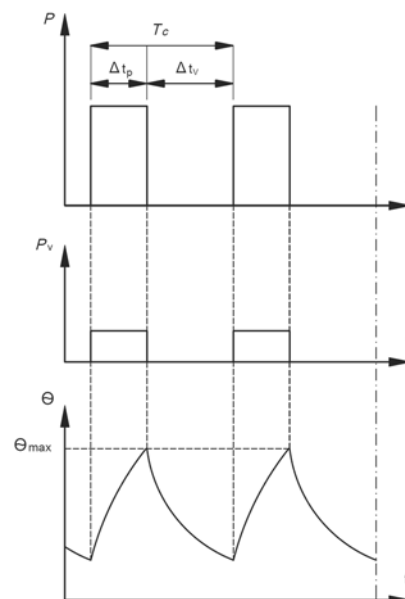

S4: Intermittent Periodic Duty with Starting

S4 has a significantly long starting time within the periodic operation. Periodic operation consists of three parts as a starting time, a time of operation at constant load and at rest.

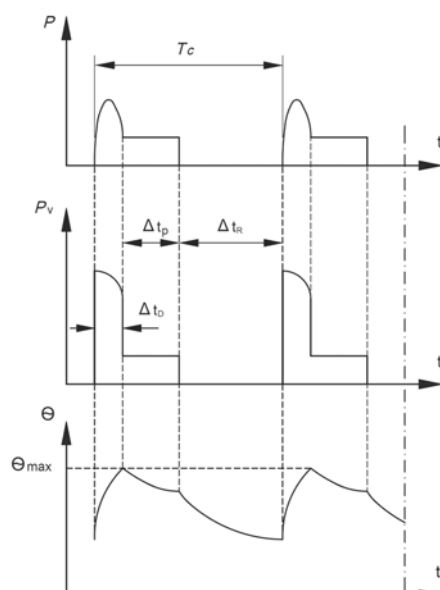

S5: Intermittent Periodic Duty with Electric Braking

Periodic operation consists of four parts: a starting time, a time of operation at constant load, a time of electric braking and at rest.

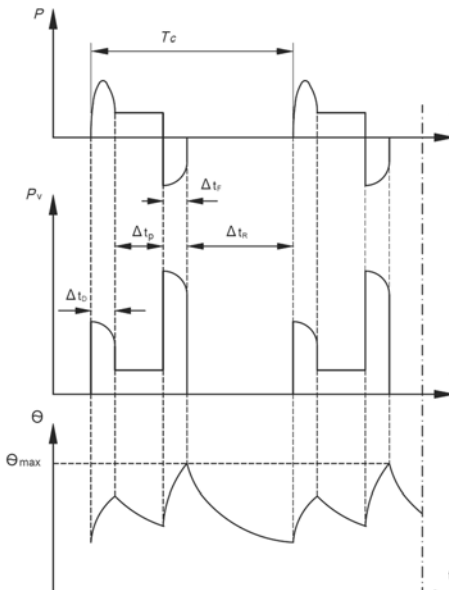

S6: Continuous Operation Periodic Duty

One duty cycle of the motor consists of period at constant load followed by a period at no-load. There is no time de-energized and at rest in this duty type.

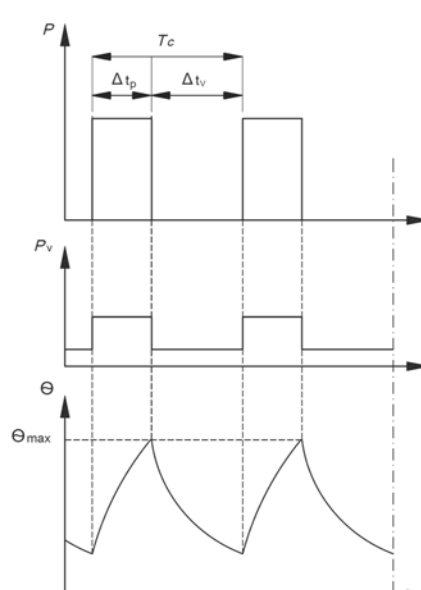

S7: Continuous Operation Periodic Duty with Electric Braking

Periodic operation consists of three parts: a starting time, a time of operation at constant load and a time of electric braking. There is no time de-energized and at rest in this duty type.

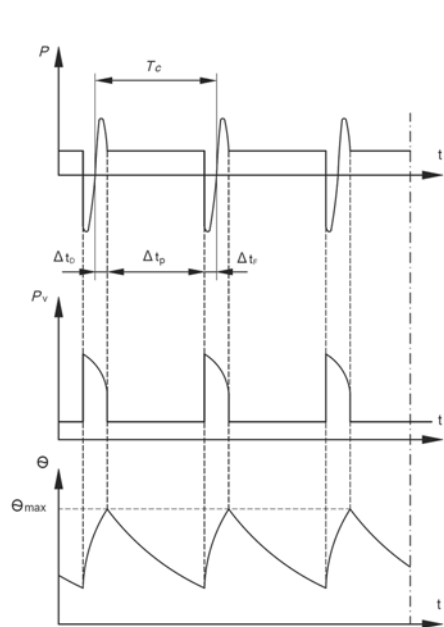

S8: Continuous Operation Periodic Duty with Related Load/Speed Changes

The motor operates at constant load corresponding to a predetermined speed of rotation, followed by one or more times of operation at other constant loads corresponding to different speeds of rotation. There is no time de-energized and at rest in this duty type.

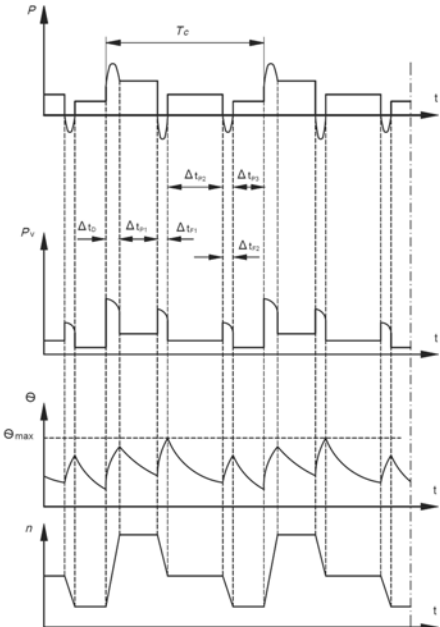

S9: Duty with Non-Periodic Load and Speed Variations

A duty in which generally load and speed vary non-periodically and includes frequently overloads.

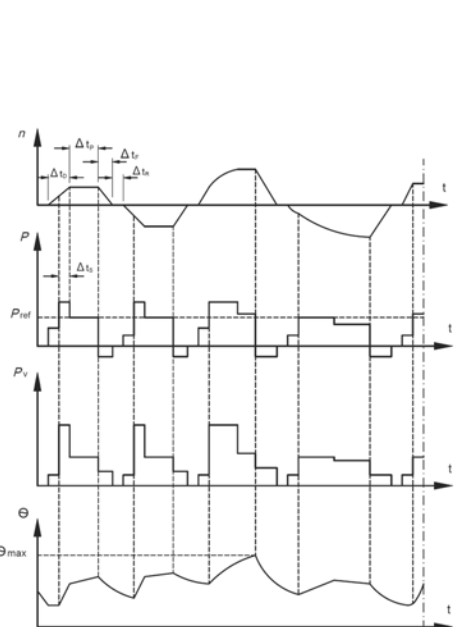

S10: Duty with Discrete Constant Loads and Speeds

The operation characterized by specific number of discrete values of load maintained for sufficient time to allow the machine to reach thermal equilibrium. The minimum load during a duty may have value zero and be relevant to a no-load or rest condition.

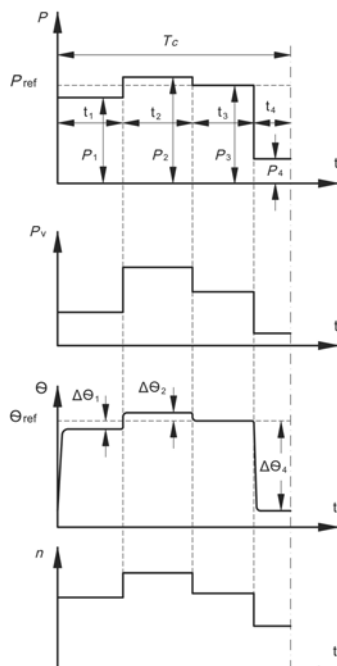

NOTE₁: Performance values given in the catalogue are valid for S1: Continuous Operation Type. Omega Motor should definitely be consulted when it is desired to run standard S1 motors in any other duty types.

The IE efficiency classes specified on the motor name plates are valid for the S1 operating state of the motor.

- P : Load
- P_V : Electrical Loss
- P_{ref} : Reference Load
- Q : Temperature
- Q_{m2x} : Maximum temperature attained
- n : Speed
- t : Time
- Δt_p : Operation time at constant time
- Δt_R : Time de-energized and at rest
- T_C : Period
- Δt_D : Starting/Accelerating time
- Δt_S : Time under overload
- Δt_F : Time of electric braking

NOTE₂: When ordering S4, S7 and S8 duty cycles, the moment of inertia of the machine must be specified by the user.

4. DEGREES OF PROTECTION

IEC 60034-5 defines the degrees of protection provided by enclosures for rotating electrical machines. However, considering the conditions in which the motors will be used, production can be made in accordance with the protection degrees IP56 (demand code K01), IP65(demand code K02) and IP66 (demand code K03).

EXAMPLE OF DESIGNATION



Motor	Degree of protection	First Numeral		Second Numeral
		Protection against contact	Protection against foreign bodies	Protection against water
Surface Ventilated	IP55	Complete protection against contact with live or moving parts.	Dust protected. Ingress of dust is not totally prevented but dust can not enter in sufficient quantity to interfere with satisfactory operation of the motors.	Protected against jets. Water projected by a nozzle against the motor from any direction shall not do any harmful effect.
	IP56			Protected against water from heavy seas.
	IP65		Dust tight. Ingress of dust is totally prevented.	Water projected by a nozzle from any direction.
	IP66			Protected against water from heavy seas.

5. COOLING METHOD



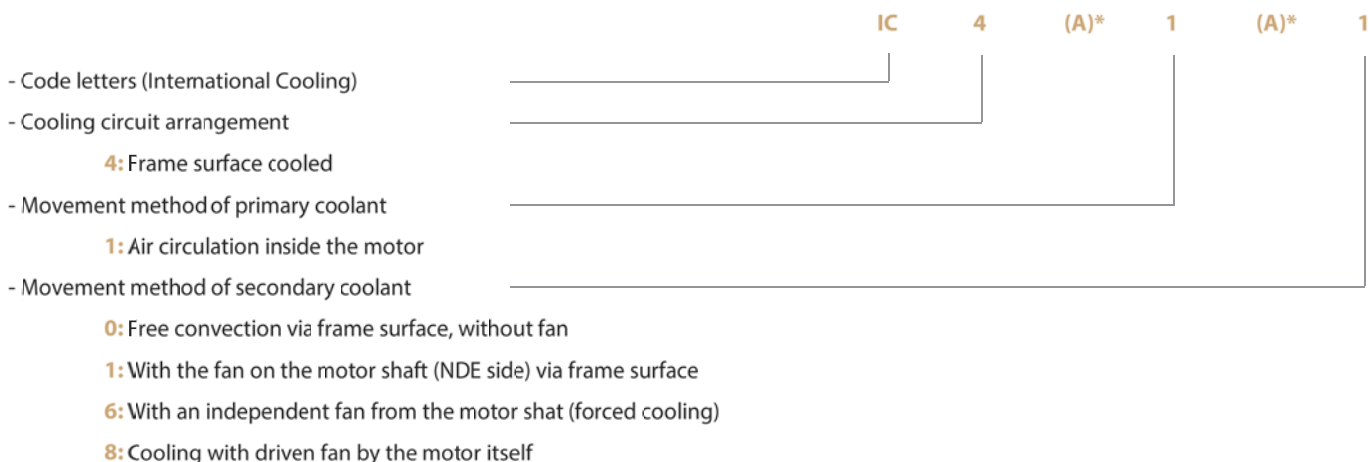



Brief information on the cooling methods, specified in IEC 60034-6, is given below.











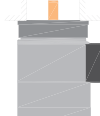

* (A): This letter indicates the surrounding medium (A for air, W for water). For air cooled motors, A is omitted for simpler designation.

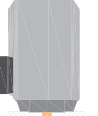
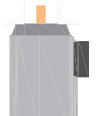
6. TYPES of CONSTRUCTION

Types of construction and mounting arrangements according to IEC 60034-7.

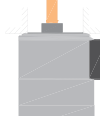
Foot Mounted Motors							
Example Sketch							
Mounting Arrangements	IM B3 IM 1001	IM B6 IM 1051	IM B7 IM 1061	IM B8 IM 1071	IM V5 IM 1011	IM V6 IM 1031	IM B10 IM 4001
Frame Size	71 - 400	71 - 400	71 - 400	71 - 400	71 - 400	71 - 400	71 - 400
Product Code	A	H	J	K	L	M	X

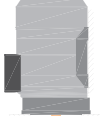
Flange Mounted Motors							
Example Sketch							
Mounting Arrangements	IM B5 IM 3001	IM V1 IM 3011	IM V3 IM 3031	IM B14 IM 3601	IM B14-2	IM V18 IM 3611	IM V19 IM 3631
Frame Size	71 - 400	71 - 400	71 - 315	71 - 160	71 - 132	71 - 160	71 - 160
Product Code	B	D	N	S	Q	Y	Z

	Motors without Foot and Endshield at D-End				Foot and Flange Mounted Motors			
Example Sketch								
Mounting Arrangements	IM B9 IM 9101	IM V8 IM 9111	IM V9 IM 9131	IM B35 IM 2001	IM V15 IM 2011	IM B34 IM 2101	IM B34-2	
Frame Size	71 - 400	71 - 400	71 - 315	71 - 400	71 - 400	71 - 160	71 - 132	
Product Code	F	P	R	C	E	T	W	

7. LIMITS OF VIBRATION SEVERITY

The permissible vibration severities for electric motors are specified in standard IEC 60034-14. All motors from frame size 71 to 400 already meet or remain below the limit values specified for vibration severity grade A (normal). Vibration severity grade A is the standard version and is valid up to a rated frequency of 60 Hz. Vibration severity grade B can be supplied on request (code B01). For converter operation with frequencies higher than 60 Hz, special balancing is required for compliance with the specified limit values.

IEC 60034-14 recommends the following maximum vibration magnitude limits in terms of displacement, speed and acceleration for a frame size H:

Vibration Grade	Frame Size	71 ≤ H ≤ 132			132 < H ≤ 280			H > 280		
		Displacement μm	Velocity mm/s	Acceleration m/s ²	Displacement μm	Velocity mm/s	Acceleration m/s ²	Displacement μm	Velocity mm/s	Acceleration m/s ²
A	Free suspension	25	1,6	2,5	35	2,2	3,5	45	2,8	4,4
	Rigid mounting	21	1,3	2,0	29	1,8	2,8	37	2,3	3,6
B	Free suspension	11	0,7	1,1	18	1,1	1,7	29	1,8	2,8
	Rigid mounting	-	-	-	14	0,9	1,4	24	1,5	2,4

Based on ISO 21940-32, the key convention "half key (H)" must be used for balancing. All rotors are balanced dynamically with an inserted half-key in place. Upon request, it is possible to perform balancing with or without a full key (order code for full key balancing is B11, and without key is B12). Shaft fitsments, such as couplings, pulleys, gears and fans must also be balanced likewise to prevent undue vibration and adverse effects on bearing life. A full feather is always inserted in the keyway on delivery. When placing an order, it's crucial to specify whether the motor shaft extension should have an open keyway, a half key or no keyway. (See page 52 for demand codes).

8. INSULATION SYSTEM

The insulation system applied in our motors ensures a high level of mechanical and electrical strength along with a very long motor life. The winding insulation is resistant against aggressive gasses, vapors, dust, oil and humid air. It helps the windings to withstand against vibration stress. This system accomplished by using mainly high grade enameled copper wires, insulating sheets, sleeves and solvent free impregnating epoxy resin.

All standard range motors are of class F (155°C) insulation with class B (80K) temperature rise which gives the product a 25°C safety margin. This temperature reserve allows the motor to be run the conditions in below. (Each of the terms applies separately, cannot be used together.)

Furthermore, this temperature reserve permits the motor to withstand against greater voltage and frequency tolerances. The insulation life of the motor will extend if the safety margin is not utilized.

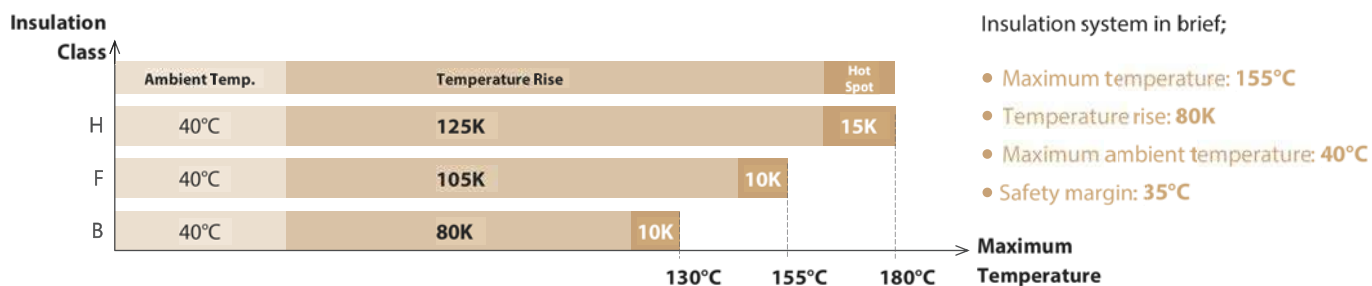

9. VARIABLE SPEED DRIVES

Squirrel cage induction motors used in industry and many other applications offer highly efficient, robust and reliable operation. The performance of motors having constant speed and starting DOL can be further improved when used with a frequency converter. The VSD enables to control the process accurately by adjusting the torque and speed. With a correct application of frequency converter, it is possible to increase the efficiency of the system and in some cases improve the capacity of the process by increasing the speed over nominal speeds.

With a VSD, it is possible to make smooth starting which helps to reduce significantly the stress on the motors and supply network.

Following points under related subtitles must be taken into consideration when motors are driven by frequency converter.

9.1. WINDING INSULATION

The output voltage waveform from a frequency converter is not fully sinusoidal. Further, harmonics will be produced in the inverter. This may affect the motor additional losses and increase the motor temperature rise. In this case, the motor must be correctly sized to compensate for the losses incurred. In addition to thermal dimensioning, an adequate torque margin must be maintained for stabilities which must be at least 30% higher than the load torque. However, standard production of Omega Motors which are IE3 premium and IE4 super premium efficiency motors, may be enough to maintain the torque and output requirements over the whole duty range without the need to oversize the motor as the temperature rise is considerably reduced due to the lower losses.

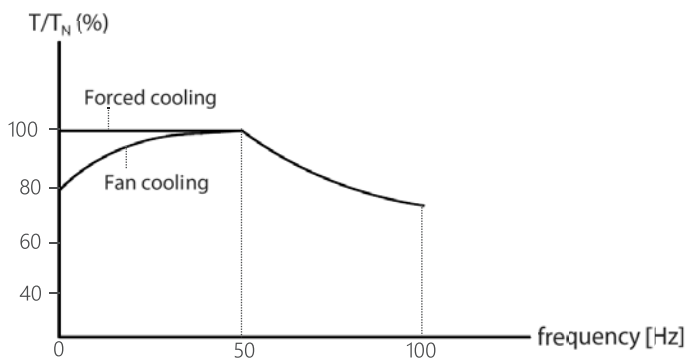

The adjacent figure gives an idea about the thermal capacity of a motor. Mechanical speed limits should be taken into consideration during the operation above nominal speeds.

Standard design induction motors of Omega Motor are capable of working with frequency converters up to 500V supply voltage without any special design. However, limit values for peak voltages and voltage rising time must be taken into consideration. Limit values for standard design motors are:

- Peak voltage $U_{\text{phase-ground}} \leq 1100 \text{ V}$
- Voltage rising time $t_s > 0.1 \mu\text{s}$

The voltage peaks at the motor terminals are mainly caused by converter switching frequency and cabling between the converter and motor. It is recommended not to exceed 5kHz switching frequency in order to protect the insulation system of the motor. In case the maximum allowed phase-to-ground (U phase-ground) voltage peaks in motor terminals as a function of pulse rise time (ts) shown in the figure below are exceeded, a special insulation system with Y02 Code must be inquired. However, if this condition can not be satisfied, filters must be used.

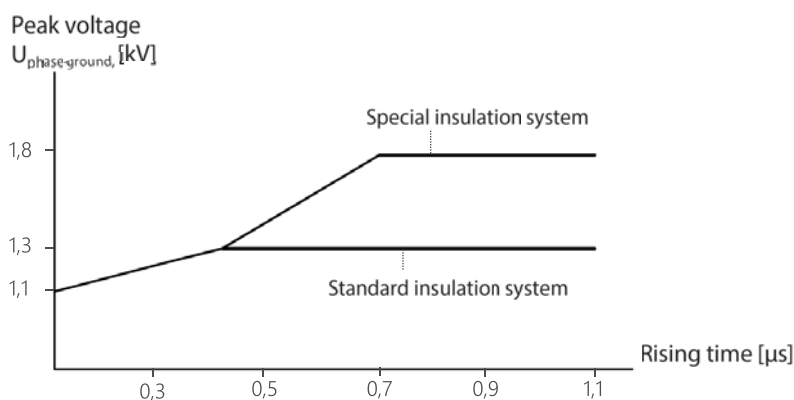

Maximum peak voltage (phase-ground) as a function of rising time.

9.2. COOLING

When the motor is operated at low speeds, the cooling capacity of the fan fitted on its shaft will decrease in a proportion,with the speed.

In variable torque loads, when the torque is reduced with decreasing speed, such as with centrifugal pumps and fans, this reduction in cooling air often stays in balance with the reduction in motor losses as the load is reduced with speed. In constant torque loads, the motor’s temperature rise limits will likely to be exceeded if the low-efficiency motor is being used in which case a forced ventilation must be considered. However, IE3 premium efficiency and IE4 super premium efficiency motors generate less heat which means they have a higher thermal reserve and may not need forced ventilation but of course this depends on the extent of the speed reduction.

In high speed applications due to magnetic field weakening , the motor torque will reduce and can only supply constant power.The output of the motor will remain constant to a certain extent depending on the breakdown torque and then will start to reduce as illustrated in below figures.

When the motor is operated in high speed (higher than 60Hz operation) standard fan will generate more noise and friction&windage losses will increase. In such cases forced ventilation is strongly recommended to prevent additional friction&windage losses and noise problem.

When placing the order, operating conditions must be stipulated.

Torque / Power

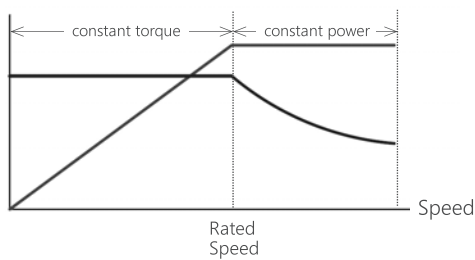

9.3. BEARING LIFE - LUBRICATION

Bearing temperature varies as a function of motor load and speed, in variable speed applications. The ideal way to determine the bearing life expectancy of permanently lubricated bearings of frame sizes 71 to 225 and lubrication intervals for the re-greaseable bearing of frame sizes 250 to 400 is best done by measuring the bearing temperature during motor operation. Please note that the lubrication periods and grease amount will be different for variable speed applications than that given in the technical catalog and motor label.

Bearing temperature of motors that are operated above their nominal speed will be higher due to friction and the lifetime of permanently lubricated bearings and lubrication period of re-greaseable bearings will become shorter.

9.4. MECHANICAL SPEED LIMITS

The permissible mechanical speed limits of Omega Motors are given at the following table. The speed limits of the bearings, critical rotor speeds and rigidity of the rotating parts determines the maximum mechanical speeds. Please note that operation at speeds higher than nominal speed may cause higher mechanical vibrations.

Frame Size	2 Pole	4 Pole	6 Pole	8 Pole	Frame Size	2 Pole	4 Pole	6 Pole	8 Pole
	rpm	rpm	rpm	rpm		rpm	rpm	rpm	rpm
71	4500	4500	4500	-	180	4500	4500	4500	4500
80	4500	4500	4500	-	200	4500	4500	4500	4500
90	4500	4500	4500	-	225	3600	3600	3600	3600
100	4500	4500	4500	-	250	3600	3600	3600	3600
112	4500	4500	4500	-	280	3600	3600	3600	3600
132	4500	4500	4500	4500	315	3600	2300	2300	2300
160	4500	4500	4500	4500	355	3600	2300	2300	2300

9.5. BEARING CURRENTS

The rapid switching in modern AC frequency converters may generate high-frequency current pulses which tend to complete their path through the motor bearings. If the energy of these pulses is high enough, this can lead to a damage on the bearings. The induced voltage on the shaft will overcome the dielectric of the lubricant in the bearing and hence cause bearing discharges known as Electrical Discharging Machining EDM effect that causes destructive pitting and damage on the bearing raceway. Beside the rise time, the cable length is a predominant factor influencing the voltage peaks occurrence at the inverter fed motor terminals. Therefore, shortening the cable length between the motor and the drive and/or using a symmetrical shielded cable will help to reduce the radiated emission through the motor cables in the Radio Frequency range (RF).

For motors lower than 100kW, the effects are usually minimal, and no additional provision needed to be made. However, for motors with an output higher than 100kW the effects become more noticeable and following additional provisions need to be made in order to eliminate the harms of bearing currents:

- Using an insulated bearing at Non-drive end side.
- Using Drive-end grounding brush.

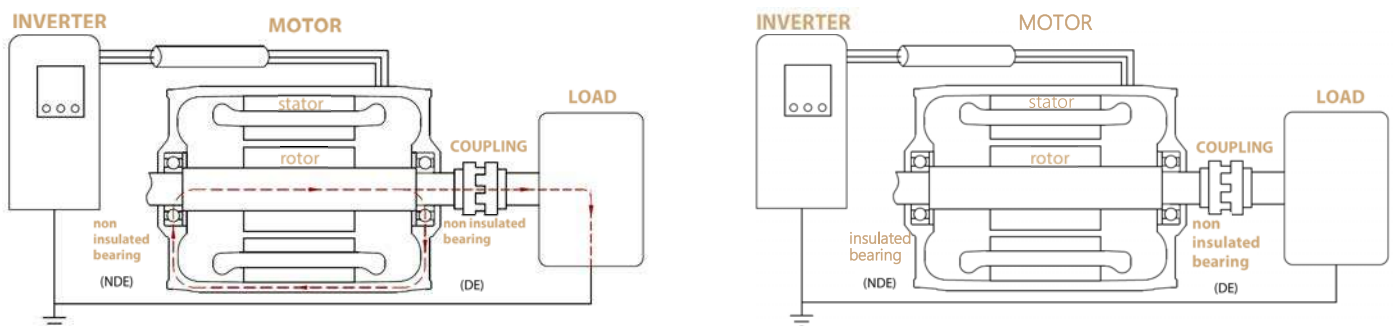

Using common-mode filters at the output of the inverter will avoid bearing currents. When placing the order, please specify if the motor is to be driven by a frequency converter.

10. TOLERANCES

According to IEC 60034-1, the following tolerances are permissible:

Parameters	Tolerances
Efficiency (η) (when determined indirectly)	- 0,15 x (1- η)
Power factor ($\cos\phi$)	1/6 (1 - $\cos\phi$) minimum absolute value: 0,02 maximum absolute value: 0,07
Total losses (applicable for machines with rated outputs > 150kW)	+10% of the total losses
Slip (s)	
Motors $P_N < 1\text{ kW}$	$\pm 30\%$ of the slip
Motors $P_N \geq 1\text{ kW}$	$\pm 20\%$ of the slip
Locked rotor current (I_L)	+20% (without lower limit)
Locked rotor torque (T_L)	+25%* of the torque -15% of the torque
Breakdown torque (T_K)	-10% (M_K/M_N still at least 1.6 after application of this tolerance)
Moment of inertia (J)	$\pm 10\%$
Noise level (sound pressure level at measuring surface)	+ 3 dB (A)

These tolerances are applicable to the warranted values for three-phase asynchronous motors, taking into account necessary manufacturing tolerances and possible deviations in the raw materials used.

* + 25% may be exceeded by agreement

In addition to the rise time, the length of the motor driver cable also has a significant effect on the peak voltages occurring at the motor terminal.

11. MECHANICAL DESIGN

11.1. FRAME, ENDSHIELDS AND FLANGES

Frame Size	71	80	90	100	112	132	160	180	200	225	250	280	315	355	400
Frame	Aluminium					Aluminium or Cast Iron					Cast Iron				
End shields (DE/NDE Sides)	Aluminium					Aluminium or Cast Iron					Cast Iron				
Flange (B5)	Aluminium					Cast Iron									
Flange (B14)	Aluminium					Cast Iron	—								
Flange (B14-2)	Aluminium					—									

11.1.1. ALUMINIUM FRAME

The motor frames are made of pressure die cast aluminium alloy from frame size 71 to 250. Frame sizes 71 to 112 have both integral and removable feet construction where terminal box is located on top in both versions. Frame sizes 132 to 225 are multi mount frames having removable/bolt-on feet and allows the motor to be left, right or top terminal box mounting position. All removable feet are made of pressure die cast aluminium alloy. Multi mount frame motors are available on top terminal box position as standard. Please inquire if left or right terminal box position is required. Frame size 250 has integral feet construction with the terminal box positioned on top.

11.1.2. CAST IRON FRAME

The motor frames are made of cast iron from frame size 160 to 400. All cast iron frames are available as with feet and without feet. Frame with feet has a solid and integrated cast feet which provide greater strength. The terminal box is always located on top as standard. The terminal box can be shifted to the right or left using a special adapter.

The cast iron frame produced of GG20 is capable to withstand against high mechanical impacts and strengths and reduce mechanical vibrations. Its unique fin design provide maximum heat dissipation and ensures excellent thermal performance of the motor.

11.2. LIFTING LUGS

Eye bolts, lifting lugs or lifting openings, if provided, are intended only for lifting the motor. These lifting provisions should never be used when lifting or handling the motor and driven ancillary equipment together. Please refer to "Motor Installation and Maintenance Guide" for further information.

To facilitate lifting to the different mounting positions, the motors have multiple points where lifting lugs are available or eyebolts can be fitted.

11.2.1. ALUMINIUM FRAME

No lifting facility is provided in frame size 71, 80 and 90S motors. Two lifting lugs integral on the top with aluminium frame are available in frame size 71, 80 and 90S motors.



The lifting lugs on the aluminium motors of the frame sizes 90L, 100 and 112 are shown in the picture.

Four lifting lugs integral with aluminium frame are available in frame size 132 to 225 motors. Once feet are bolt on the frame, two lifting lugs opposite to each other can be used to lift the horizontal motor no matter if the terminal box is on top, right or left position.

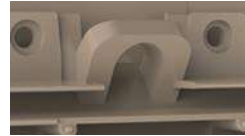
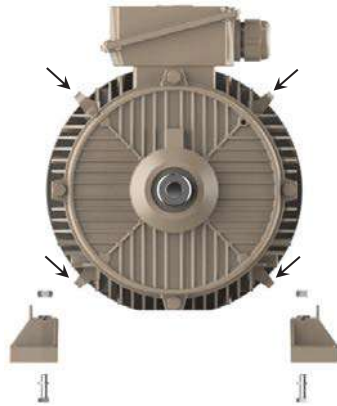

The lifting lugs on the aluminium motors of the frame sizes **132, 160, 180, 200** and **225** are shown in the picture.

Furthermore, in cases where additional lifting lugs are necessary, two optional points are available for fitting DIN580 eyebolts on the right and left position of aluminium frame motors in frame size 90 to 160. In frame sizes 160 to 225, there is one optional point available for fitting DIN580 eyebolts, which must be requested with an option code of X06. One DIN580 eyebolt fitted on top for frame size 250 as standard. One additional DIN580 eyebolt can be fixed bottom when needed and it has to be inquired with an option code X05.

11.2.2. CAST IRON FRAME

Two lifting lugs integral with cast iron frame are available in frame sizes 160, 180, 200 and 225. Moreover, two additional points are available for fitting DIN580 eyebolts, one top (demand code X04) and the other one bottom (demand code X05).



The lifting lugs on the cast iron motors of the frame sizes **160, 180, 200** and **225** are shown in the picture.

One DIN580 eyebolt fitted on top for frame size 250 to 400 as standard. One additional DIN580 eyebolt can be fixed bottom when needed and it has to be inquired with an option code X05.



The lifting lugs on the cast iron motors of the frame sizes **250, 280, 315, 355** and **400** are as shown in the picture. The lifting lugs on the aluminium motors of the frame size **250** is shown in the picture.

11.3. EXTERNAL FINISH

Omega Motors are protected with a range of surface finishes as shown below.

Surface	Parts	Treatment
Cast Iron	End shields, Housing	Shot blasting + Primer
Steel	Fan Cover	Zinc galvanized
Aluminium alloy	Housing, End shields, Terminal boxes, Bearing caps	Shot blasting
Polymer	Ventilation fans	None

Standard paint system of Omega Motor;

Motors	Atmosphere	Applications	Corrosivity Category Acc. to ISO 12944-2
71 to 112 Aluminum Frame	Non-harsh and not very harsh (indoors, industrial)	Acrylic -based paint	C3
132 to 225 Aluminum Frame	Moderately corrosive, humid and outdoors (temperate climate)	2 pack (water based) Epoxy resin based paint 50µm	
160 to 400 Cast Iron Frame			

Paint can be applied in accordance with the C5 corrosion class upon request (demand code B53).

Omega motor standard paint color reference:



11.4. SHAFT EXTENSION

All standard design motors are produced with one shaft extension and fitted with a proper shaft key in accordance with IEC 60072-1. Motors with second standard shaft extension can be delivered upon request with special order code M30. The shaft ends have a 60° center hole to DIN332, Part 2 with M5 to M24 tapped hole depending on the shaft diameter.

11.5. VIBRATION MEASURING POINTS AND NIPPLES

There is one flat area on the drive and non drive end of the motors from frame size 71 to 112, for better placement of accelerometer or vibration tester. Motors of frame size 132 to 400 have four of these flat areas on both ends. Measuring nipples for SPM (shock pulse measurement) are optionally possible to check the bearings (demand code R02).



11.6. DRAIN HOLES

There are drain holes at both ends of the frame for drainage of water that may condense inside of the enclosure.

These drain holes are situated underneath of the frame as standard for horizontal mounting arrangement where the terminal box is on top. Condensation drain holes can also be implemented in motors designed for vertical operation (shaft up or down), feet located or side or top provided that it is inquired with the order. Motors with a protection degree of IP55 are delivered with plugs closed. It is advisable to periodically open the drain plugs in order to ensure that the condensed water drains out. When opened, the enclosure degree of protection will reduce to IP44.

The open and closed positions of drain plugs are illustrated below.

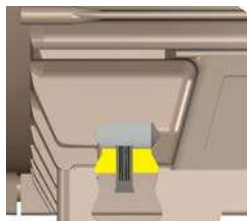

Drain hole open position

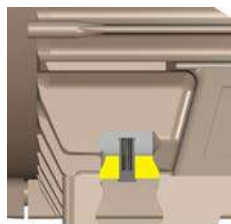

Drain hole is close position

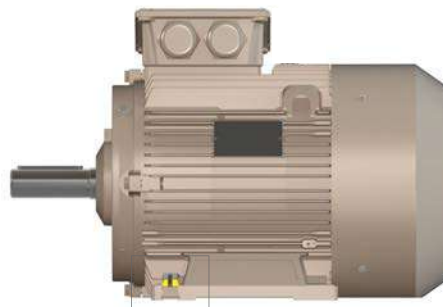

- Location of drain hole depends on motor's mounting arrangement and frame material. These pictures are given for IM B3, aluminium frame motors.

11.7. ANTI-CONDENSATION HEATING ELEMENTS

Heating elements are used to protect the windings of the motor against condensation. The use of anti-condensation heaters are recommended for motors installed in highly humid environments and left idle for long periods or for motors that are subjected to widely fluctuating temperatures. The supply voltage for anti-condensation heaters must be defined by the customer. It can be either 110V (demand code H01) or 220V (demand code H02).

Anti-condensation heaters must be energized when the motor is switched off and de-energized when the motor is switched on.

An additional M20 cable gland is provided for the connecting cable in the terminal box.

The power rating and number of anti-condensation heaters corresponding to the frame sizes are indicated in the below table:

Frame Size	71	80	90	100	112	132	160	180	200	225	250	280	315	355	400	
No. of Heaters x Output Power	2 x 20W				2 x 30W				2 x 40W				2 x 60W			

Instead of anti-condensation heaters, another alternative is to apply a low voltage that is approximately 5 to 10% of motor rated voltage to stator terminals U1 and V1 by means of auto-transformer. After the motor is de-energized 20% to 30% of the motor rated current will be enough to heat the motor.

11.8. COOLING

All standard motors are totally enclosed and fan cooled (TEFC)-IC411 as per IEC 60034-6. Motors frame size 71 to 400 have radial flow fan, fitted on the non-drive end shaft of the motor and operate regardless of the direction of rotation. The air flows from the non-drive end (NDE) to drive end (DE) direction. Totally enclosed non-ventilated (TENV) – IC410, totally enclosed air over (TEAO) – IC418 and totally enclosed forced ventilated (TEFV) – IC416 versions are also available on request.

The standard fan impeller is made out of plastic. Where necessary, metal fan impeller can also be supplied on request (order code is S10). The fan covers of all motors are made of sheet metal by drawing to its final shape.

For motors having vertical shaft extension pointing upwards, the end user must prevent, ingress of fluid along the shaft. Downwards, a protective cover (canopy) is recommended. When the motors are installed outdoors, over a long period of time, they must be protected with a sort of cover against direct intensive solar radiation, rain, snow, ice or dust.

When the motor is mounted to a place where the air intake is restricted, it must be ensured that minimum clearance is maintained between the fan cover and the restricted element. This restriction may be caused either by a wall or any adjacent part fitted on the non-drive end shaft of the motor like flywheels or large hand wheels. Recommended minimum clearance between the wall and fan cover;

Frame Size	71	80	90	100	112	132	160	180	200	225	250	280	315	355	400	
Clearance [mm]	25			30			45		60		90		110			

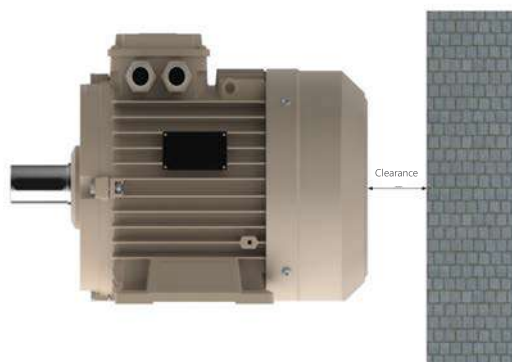

11.9. CABLE GLAND

Cable entry to the terminal box is maintained by means of polyamide cable glands produced according to DIN EN 62444 and sealed with IP68 protection degree. Motors from frame size 71, 80 and 90 have one and motors of frame sizes 100 and 112 have two snap-in glands and are fitted on right when viewed from drive end shaft extension. Motors from frame size 132 to 400 have two glands with thread and are fitted on right when viewed from drive end shaft extension.

Frame Size	71	80	90	100	112	132	160	180	200	225	250	280	315	355	400	Cable Glands for Accessories	
Cable Glands	1 x M25		2 x M25		2 x M32		2 x M40		2 x M50		2 x M63					M20	PG9
Max. Cable Outer Diameter [mm]	Ø13		Ø13		Ø21		Ø32		Ø39		Ø46					Ø10	Ø6
Min. Cable Outer Diameter [mm]	Ø10		Ø10		Ø12		Ø18		Ø27		Ø33					Ø4	Ø2

11.10. TERMINAL BOX

The terminal box of all frame sizes is made of high pressure die-cast aluminium alloy and positioned towards the drive end of the motor. This arrangement improves the air flow over the cooling fins, and reduces the motor operating temperature.

From frame size 132 to 400, it is diagonally split for easier access and handling of leads and connections. It allows cable entry from both sides simply by rotating the terminal box 180°.

From frame size 71 to 112, terminal box is integrally cast with the aluminium motor frame. Cable entry is maintained by means of readily fit snap-in cable gland. It also permits cable entry from opposite side by removing the aluminium knockout. The cable entries can be connected with one M20 and one M25 cable glands when this option is applied.

All motors from frame size 71 to 400 are provided with earth terminal on the frame inside the terminal box.

Accessory terminals are assembled on connectors whenever the motor is supplied with thermistors, thermostats, PT100 monitoring sensors or anti-condensation heaters. A M20 cable gland is fitted for the incoming connection leads. PG9 is added if there is brake and/or forced cooling.

The motor terminal block is made from thermoplastic material duly reinforced with fiber glass. It has six terminals with sizes given below.

Frame Size	71	80	90	100	112	132	160	180	200	225	250	280	315	355	400
Terminal Size	M4 x 12					M5 x 19	M6 x 24		M8 x 28		M10 x 34		M12		

*External earth terminal is standard for frame size 250 to 400 motors. It is located on the foot.

For **71 to 112** frame sizes terminal box, terminal and cable outputs are shown above.

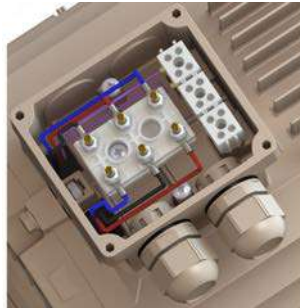

For **315, 355 and 400** frame sizes terminal box, terminal and cable outputs are shown above.



For **132** frame size terminal box, terminal and cable outputs are shown above.



For **160 to 280** frame sizes terminal box, terminal and cable outputs are shown above.

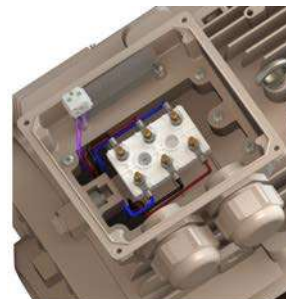

11.11. BEARINGS

The standard bearing configuration of Omega Motor is single row deep groove ball bearings. The maximum permissible radial and axial forces are given at pages 24 to 27. Reinforced design with cylindrical roller bearing at DE should be considered in applications where high radial load is available and exceeding the values given for standard design at page 24. Roller bearings are suitable for belt and pulley applications. When high axial loads greater than the values given for standard design at pages 25, 26 and 27 are available, then angular contact ball bearing should be used. When ordering a motor with an angular contact ball bearing, specify also the method of mounting and the direction and magnitude of axial force.

Frame Size	Number of Poles	Standard design Deep groove ball bearing			Reinforced design for high radial forces NU bearing at DE			Reinforced design for high axial forces Angular contact ball bearing at DE		
		Drive end (DE) bearing	Non-drive end (NDE) bearing	Fig. No.	Drive end (DE) bearing	Non-drive end (NDE) bearing	Fig. No.	Drive end (DE) bearing	Non-drive end (NDE) bearing	Fig. No.
71	2-6	6202 ZZ/CM		1	-		-	-		-
80	2-6	6204 ZZ/CM			-			-		
90	2-6	6205 ZZ/CM			-			-		
100	2-6	6206 ZZ/CM			-			-		
112	2-6	6206 ZZ/CM			-			-		
132	2-8	6208 ZZ/C3		2	-		-	-		-
160	2-8	6309 ZZ/C3	6209 ZZ/C3		NU 309 E/CN	6309 C3		6309 C3	7309 B	
180	2-8	6310 ZZ/C3	6210 ZZ/C3		NU 310 E/CN	6310 C3		6310 C3	7310 B	
200	2-8	6312 ZZ/C3	6212 ZZ/C3		NU 312 E/CN	6312 C3		6312 C3	7312 B	
225	2-8	6313 ZZ/C3	6213 ZZ/C3		NU 313 E/CN	6313 C3		6313 C3	7313 B	
250	2-8	6315 C3		3	NU 315 E/CN	6315 C3	6315 C3	7315 B	6	
280	2-8	6316 C3			NU 316 E/CN	6316 C3	6316 C3	7316 B		
315	2									
315	4-8	6319 C3		4	NU 319 E/CN	6319 C3	6319 C3	7319 B		
355	2	6317 C3			NU 317 E/CN	6317 C3	6317 C3	7317 B		
355	4-8	6322 C3			NU 322 E/CN	6322 C3	6322 C3	7322 B		
400	2	6317 C3			NU 317 E/CN	6317 C3	6317 C3	7317 B		
400	4-8	6324 C3			NU 324 E/CN	6324 C3	6324 C3	7324 B		

Standard design with deep groove ball bearings

From frame size 71 to 225, the motors are fitted with double shielded (ZZ) deep groove ball bearings which are factory grease packed for life. Motors of frame size 250 to 400 have open type single row deep groove ball bearings and are equipped with greasing nipples for re-lubrication during operation.

Motors from frame size 71 to 112 have floating bearings at both drive end and non-drive end (see Fig.1). On request, axially-secured located bearing can be supplied on the drive end (DE) complete with a retaining ring to avoid the play of the shaft (demand code R20).

The non-drive end bearings of motors from frame size 132 to 225 are axially located with a retaining ring (see Fig.2). From frame size 250 upwards, the located bearing is axially secured at drive end with a bearing cap (see Fig.3 and Fig.4).

Motors from frame size 160 to 225 can be supplied with NDE bearing upgraded to the size of DE bearing on request with the configuration of Fig.2.

In frame sizes 132 to 225, if required, the drive end (DE) bearing can be located with a retaining ring. A located bearing at the drive end (DE) is recommended when gearing is installed or pumps and fans are mounted directly on the motor shaft.

To compensate for any axial movement of the shaft, the motors are fitted with pre-load washers up to frame size 71 to 112 at NDE, frame sizes 132 to 225 at DE and frame sizes 250 and 280 at NDE. Motors of frame size 315/4, 355 and 400 have pre-load springs located at NDE (see Fig.4).

Reinforced design with NU cylindrical roller bearing

Reinforced design with NU cylindrical roller bearing is recommended for belt and pulley application in cases where the permissible radial force values given for standard deep groove ball bearing design at page 24 is not enough.

Motors from frame size 160 upwards can be supplied with cylindrical roller bearings. The non-drive end (NDE) bearing is located and the axial movement is compensated by the axial play of the drive end (DE) roller bearing. (see Fig.5)

For NU cylindrical roller bearings, in contrast to ball bearings, a minimum radial force is required to ensure proper operation. Cylindrical roller bearings are not suitable for coupling arrangement and high speed operation.

Reinforced design with angular contact ball bearing

Reinforced design with angular contact ball bearing is recommended for applications where the permissible axial force values given at pages 25, 26 and 27 is not enough. When ordering a motor with an angular contact ball bearing, specify also the method of mounting, direction and magnitude of axial force.

Motors from frame size 160 upwards can be supplied with angular contact ball bearings. The non-drive end (NDE) bearing is located and the axial movement is compensated by the pre-load washers/springs at drive end (DE). (see Fig.6)

Motors with roller bearings or angular-contact ball bearings are fitted with a transport lock before dispatch to prevent damage to bearings during transport. The transport lock must be removed before operation.

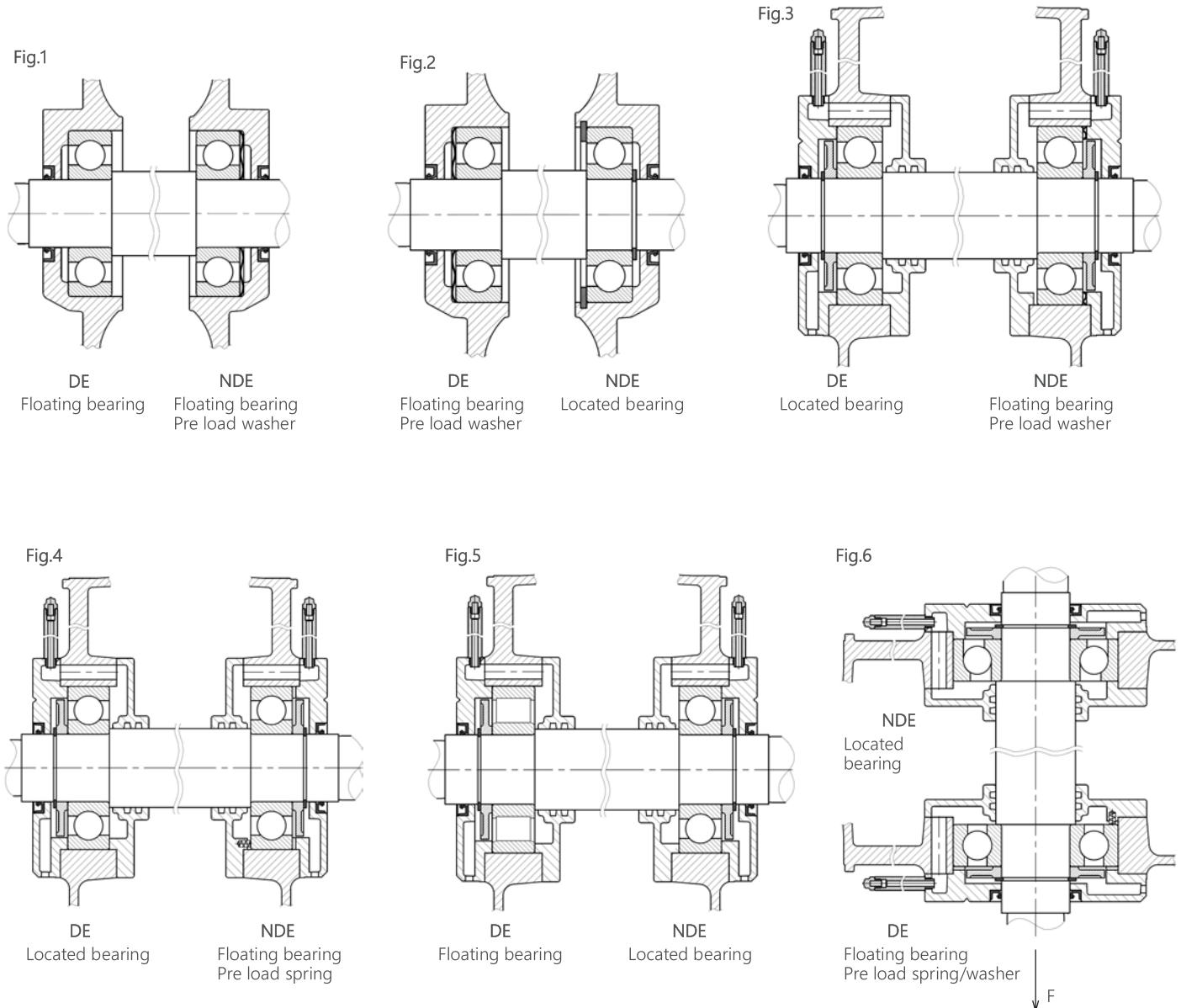

11.11.1. BEARING LIFETIME AND LUBRICATION

The lifetime of a bearing is expressed as the number of revolutions or the number of operating hours at a given speed that the bearing can accomplish before the first sign of metal fatigue (spalling) begins to appear on a raceway of the inner or outer ring or a rolling element.

The nominal bearing lifetime L10h as defined in ISO 281 is the life that 90% of a sufficiently large group of apparently identical bearings can be expected to reach or exceed when operating under conventional conditions, i.e. after a stated amount of time 90% of a group of identical bearings will not yet have developed metal fatigue. The majority of bearings last much longer than the nominal lifetime; the average lifetime achieved or exceeded by 50% of bearings is around 5 times longer than the nominal lifetime.

Generally, the lifetime of the bearing is dependent on its type and size, the radial and axial mechanical loads it is submitted to, operating conditions (environment, temperature, mounting orientation), rotational speed and grease life. Therefore, bearing lifetime is closely related to its correct use, maintenance and lubrication. A bearing lifetime calculation is possible on request.

The approximate bearing life of four-pole motors at 50 Hz operation with horizontal mounting is about 40000 hours if there is no additional axial or radial forces when direct coupled to the load and 20000 hours when utilized according to the maximum admissible loads given in pages 24 to 27. The nominal bearing lifetime is reduced for converter operation at higher frequencies.

11.11.1.1. Motors with bearings greased for life

Motors in frame size 71 to 225, are fitted with double shielded (ZZ) deep groove ball bearings which are factory grease packed for life. The bearing grease lifetime is matched to the bearing lifetime. This can, however, only be achieved if the motor is operated in accordance with the catalog specifications.

11.11.1.2. Motors with relubrication nipples

Motors in frame size 250 to 400 have open type single row deep groove ball bearings and are equipped with greasing nipples for re-lubrication during operation. On request, motors in frame size 160 to 225 can be equipped with greasing nipples. In aluminium frame motors, both DE and NDE end shields will be cast iron if regreasing facility is requested.

Bearings are lubricated with high quality grease containing lithium soap (thickener) and mineral oil (base).

The quantity of grease and lubrication intervals are stamped in the motor nameplate. The lubrication intervals are shown in table below. It must be emphasized that excessive lubrication, i.e. a quantity of grease greater than that recommended in below table and on the motor nameplate, can result in the increase of bearing temperatures leading to reduced operating hours. Respecting the quantity of grease and lubrication intervals allows bearings to reach the lifetime given.

High speeds that exceed the rated speed with converter operation and the resulting increased vibrations alter the mechanical running smoothness and the bearings are subjected to increased mechanical stress. This reduces the grease lifetime and the bearing lifetime.

Lubrication intervals for deep groove ball bearing

Frame Size	Grease Amount		Lubrication Intervals (hour)			
	Drive end (DE) Bearing	Non-drive end (NDE) Bearing	2 Pole 3000 rpm	4 Pole 1500 rpm	6 Pole 1000 rpm	8 Pole 750 rpm
	g	g	hour	hour	hour	hour
160	12	12	8500	16000	20000	22000
180	15	15	7500	15000	19000	21000
200	20	20	6000	13000	17000	20000
225	23	23	5000	12000	16500	19000
250	30	30	4000	11000	15000	18000
280	33	33	3500	10000	14500	17000
315	33	33	2500	-	-	-
315	45	45	-	8500	13000	16000
355	40	40	2000	-	-	-
355	60	60	-	5000	11000	14000
400	40	40	2000	-	-	-
400	75	75	-	3500	8000	12000

Lubrication intervals are given above for both standard design housing and alternative design housing against over radial forces.

Lubrication intervals for NU cylindrical roller bearing

Frame Size	Grease Amount		Lubrication Intervals (hour)			
	Drive end (DE) Bearing	Non-drive end (NDE) Bearing	2 Pole 3000 rpm	4 Pole 1500 rpm	6 Pole 1000 rpm	8 Pole 750 rpm
	g	g	hour	hour	hour	hour
160	12	12	4300	8000	10000	11000
180	15	15	3800	7500	9500	10500
200	20	20	3000	6500	8500	10000
225	23	23	2500	6000	8300	9500
250	30	30	2000	5500	7500	9000
280	33	33	1800	5000	7300	8500
315	33	33	1300	-	-	-
315	45	45	-	4300	6500	8000
355	40	40	1000	-	-	-
355	60	60	-	2500	5500	7000
400	40	40	1000	-	-	-
400	75	75	-	1800	4000	6000

11.11.2. PERMISSIBLE RADIAL FORCES

In pulley and belt couplings, the drive shaft carrying the pulley is subjected to a radial force F_R applied at a distance X (mm) from the shoulder of the shaft extension (length E). The line of force (i.e. the centerline of the pulley) of the radial force must lie within the free shaft extension (dimension x).

The radial force F_R expressed in N applied to the drive shaft is found by the formula.

$$F_R = 1,9 \cdot \frac{P \cdot k}{D \cdot n} \cdot 10^7$$

- F_R = Radial force in N
- n = rated motor speed in rpm
- P = Rated motor power (transmitted power) in kW
- D = Pulley diameter in mm
- k = Belt tension factor, dependent on belt type and type of duty

The belt tension factor k is a value gained from experience from the belt manufacturer. The following approximate value can be assumed:

- $k = 1$ to 1.5 for toothed belts
- $k = 2$ to 2.5 for V-belts
- $k = 2.5$ to 3 for flat belts with tensioner
- $k = 3$ to 4 for flat belts without tensioner

If the radial force is applied between points X_0 and X_{max} , the permissible force F_R can be calculated with the following formula:

$$F_R = F_{X0} - \frac{X}{E} (F_{X0} - F_{Xmax})$$

Where E stands for length of the shaft extension in the standard version.

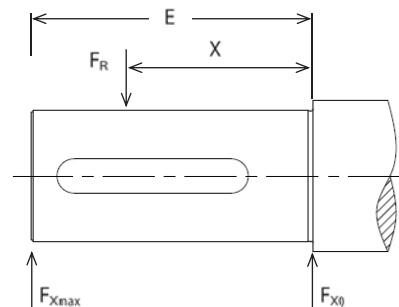

The following table shows permissible radial forces on the shaft in Newton, assuming zero axial force ($F_A=0$), 20 000 hours bearing life and 50 Hz operation. Please consult for values at 60 Hz. operation.

Standard design with deep groove ball bearing ($F_A = 0$)

Pole Number	2 Pole			4 Pole			6 Pole			8 Pole		
			Shaft Extension E			Shaft Extension E			Shaft Extension E			Shaft Extension E
	F_{X0}	F_{Xmax}		F_{X0}	F_{Xmax}		F_{X0}	F_{Xmax}		F_{X0}	F_{Xmax}	
Frame Size	N	N	mm	N	N	mm	N	N	mm	N	N	mm
71	433	365	30	548	462	30	628	530	30	-	-	-
80	716	591	40	903	745	40	1036	855	40	-	-	-
90	800	653	50	1007	823	50	1157	945	50	-	-	-
100	1103	882	60	1387	1109	60	1597	1277	60	-	-	-
112	1100	890	60	1386	1121	60	1595	1290	60	-	-	-
132	1610	1275	80	2000	1580	80	2300	1820	80	2530	2000	80
160	3000	2400	110	3750	3000	110	4300	3440	110	4730	3785	110
180	3500	2840	110	4370	3540	110	5045	4090	110	5570	4515	110
200	4580	3820	110	5700	4750	110	6600	5500	110	7280	6070	110
225	5095	4270	110	6400	5145	140	7430	5970	140	8230	6610	140
250	6175	5060	140	7760	6365	140	9035	7410	140	9995	8195	140
280	6570	5525	140	8130	6835	140	9545	8025	140	10580	8895	140
315	5879	5063	140	8361	7165	170	9759	8364	170	10982	9412	170
355	4947	4347	170	12000	10000	210	14000	11500	210	15700	12300	210
400	4132	3648	170	12385	10636	210	15070	12942	210	16951	14558	210

Reinforced design with NU cylindrical roller bearing ($F_A = 0$)

Pole Number	2 Pole			4 Pole			6 Pole			8 Pole		
			Shaft Extension E			Shaft Extension E			Shaft Extension E			Shaft Extension E
	F_{X0}	F_{Xmax}		F_{X0}	F_{Xmax}		F_{X0}	F_{Xmax}		F_{X0}	F_{Xmax}	
Frame Size	N	N	mm	N	N	mm	N	N	mm	N	N	mm
160	7505	6000	110	9200	7360	110	10400	8315	110	11330	9060	110
180	8430	6830	110	10330	8370	110	11700	9485	110	12775	10350	110
200	11490	9580	110	14070	11730	110	15955	13300	110	17410	14515	110
225	13637	11437	110	16765	13470	140	19025	15280	140	20780	16700	140
250	18075	14820	140	22220	18220	140	25230	20685	140	27545	22585	140
280	19340	16265	140	23645	19880	140	26920	22640	140	29410	24734	140
315	18202	15676	140	29668	25427	170	33660	28847	170	36910	31630	170
355	20185	17737	170	38600	31800	210	43700	36000	210	47900	39500	210
400	19409	17136	170	47478	40775	210	54451	46764	210	46842	40229	210

11.11.3. PERMISSIBLE AXIAL FORCES

The following table shows permissible axial forces on the shaft in Newton, assuming 20 000 hours bearing life and 50 Hz operation. Please consult for values at 60 Hz. operation.

11.11.3.1. HORIZONTAL MOUNTING

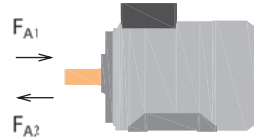

Standard design with deep groove ball bearing

Pole Number	2 Pole				4 Pole				6 Pole				8 Pole			
	F _{A1}			F _{A2}	F _{A1}			F _{A2}	F _{A1}			F _{A2}	F _{A1}			F _{A2}
	F _R =0	F _R =max		F _R =0	F _R =0	F _R =max		F _R =0	F _R =0	F _R =max		F _R =0	F _R =0	F _R =max		F _R =0
		F _{X0}	F _{Xmax}			F _{X0}	F _{Xmax}			F _{X0}	F _{Xmax}			F _{X0}	F _{Xmax}	
Frame Size	N	N	N	N	N	N	N	N	N	N	N	N	N	N	N	N
71	238	23	23	100	358	53	53	100	440	93	92	100	-	-	-	-
80	406	61	61	132	590	128	128	150	730	173	173	132	-	-	-	-
90	412	35	36	176	609	109	109	160	765	158	159	176	-	-	-	-
100	549	35	35	252	812	133	133	220	1029	204	203	252	-	-	-	-
112	545	36	36	252	808	134	134	220	1024	204	204	252	-	-	-	-
132	1050	970	840	1650	1475	1365	1190	2075	1814	1685	1465	2415	2060	1920	1690	2660
160	1155	1045	800	1655	1585	1435	1135	2085	1935	1740	1375	2435	2200	2000	1575	2700
180	1380	1260	990	1900	1880	1710	1380	2400	2300	2090	1650	2820	2625	2410	1930	3145
200	2065	1895	1595	2565	2760	2545	2175	3255	3340	3075	2615	3840	3825	3515	2980	4325
225	2345	2140	1815	2905	3160	2910	2420	3720	3835	3520	2915	4395	4405	4035	3325	4965
250	5305	2805	2805	4765	6890	3625	3625	6350	8150	4220	4220	7610	9210	4720	4720	8670
280	5495	2930	2930	5000	7125	3805	3805	6625	8445	4430	4430	7945	9525	4945	4945	9025
315	5290	2928	2929	4730	7869	4430	4430	7270	9252	5147	5147	8652	10466	5745	5745	9865
355	4995	3173	3173	4395	10300	5630	5630	9700	1250	6600	6600	11500	13700	6750	6750	13100
400	4680	3173	3173	4080	10872	6186	6186	10272	13224	7268	7268	12625	14900	8106	8106	14300

Reinforced design with NU cylindrical roller bearing

Pole Number	2 Pole				4 Pole				6 Pole				8 Pole			
	F _{A1}			F _{A2}	F _{A1}			F _{A2}	F _{A1}			F _{A2}	F _{A1}			F _{A2}
	F _R =0	F _R =max		F _R =0	F _R =0	F _R =max		F _R =0	F _R =0	F _R =max		F _R =0	F _R =0	F _R =max		F _R =0
		F _{X0}	F _{Xmax}			F _{X0}	F _{Xmax}			F _{X0}	F _{Xmax}			F _{X0}	F _{Xmax}	
Frame Size	N	N	N	N	N	N	N	N	N	N	N	N	N	N	N	N
160	2445	2165	1570	2445	3210	2835	2105	3210	3825	3355	2790	3825	4275	3805	2805	4275
180	2830	2520	1900	2830	3710	3310	2540	3710	4420	3930	3015	4420	4980	4455	3400	4980
200	3690	3270	2535	2690	4815	4295	3380	4815	5735	5095	4015	5735	6490	5765	4525	6490
225	4160	3625	2795	4160	5460	4810	3505	5460	6505	5710	4215	6505	7380	6470	4755	7380
250	5050	4290	3110	5050	6630	5715	4135	6630	7895	6780	4985	7895	8955	7660	5640	8955
280	5260	4600	3495	5260	6890	6090	4595	6890	8215	7235	5550	8215	9295	8165	6290	9295
315	4878	3994	3108	5378	7638	6357	4770	7638	9025	7610	5700	9025	10243	8615	6530	10243
355	4717	4241	3379	4717	10100	9330	7380	10100	11940	10800	7800	11940	13400	12300	8900	13400
400	4397	3969	3161	4397	10630	9419	7063	10630	12981	11489	8574	14980	14658	13441	10797	14658

11.11.3.2. VERTICAL MOUNTING

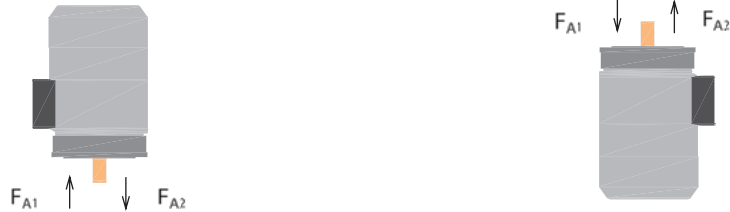

Standard design with deep groove ball bearings

Frame Size	Pole Number	Shaft Down						Shaft Up					
		FA1			FA2			FA1			FA2		
		FR= max		FR= 0	FR= max		FR= 0	FR= max		FR= 0	FR= max		FR= 0
		Fx0	Fxmax		Fx0	Fxmax		Fx0	Fxmax		Fx0	Fxmax	
N	N	N	N	N	N	N	N	N	N	N	N	N	
71	2	120	120	120	7	13	223	80	80	80	43	43	259
	4	120	120	120	48	52	345	80	80	80	84	84	380
	6	120	120	120	78	78	426	80	80	80	114	113	462
80	2	157	157	157	39	39	385	107	107	107	88	88	434
	4	162	162	162	101	104	566	102	102	102	162	162	627
	6	162	162	162	147	143	705	102	102	102	208	208	766
90	2	211	211	211	3	-	381	141	141	141	78	78	456
	4	221	221	221	47	45	572	131	131	131	162	162	667
	6	226	226	226	119	117	728	126	126	126	217	217	826
100	2	307	307	307	-	-	501	197	197	197	100	100	615
	4	322	322	322	69	65	751	182	182	182	218	218	900
	6	332	332	332	141	143	973	172	172	172	295	295	1127
112	2	322	322	322	-	-	486	182	182	182	117	117	629
	4	347	347	347	56	52	735	157	157	157	247	247	926
	6	347	347	347	129	130	957	157	157	157	315	315	1143
132	2	1120	990	1200	1450	1325	1530	850	720	930	1720	1590	1800
	4	1580	1405	1695	1760	1585	1870	1160	980	1270	1580	1405	2295
	6	1895	1670	2015	2080	1860	2205	1480	1260	1605	2495	2270	2615
	8	2180	1960	2320	2285	2070	2420	1685	1465	1820	2780	2560	2920
160	2	1325	1085	1440	1280	1040	1390	780	540	890	1825	1585	1940
	4	1840	1535	1995	1555	1250	1710	1055	750	1210	2340	2035	2495
	6	2160	1785	2355	1830	1455	2025	1330	955	1525	2660	2285	2855
	8	2470	2040	2660	2040	1610	2235	1540	1115	1735	2970	2540	3160
180	2	1700	1430	1825	1430	1160	1550	910	640	1030	2220	1950	2350
	4	2310	1970	2485	1725	1390	1900	1205	865	1380	2830	2490	3005
	6	2740	2320	2960	2110	1690	2330	1590	1170	1810	3260	2840	3480
	8	3070	2595	3285	2400	1925	2620	1880	1405	2100	3590	3115	3810
200	2	2525	2210	2680	1895	1585	2050	1395	1080	1550	3025	2710	3180
	4	3460	3080	3675	2285	1900	2500	1785	1405	2000	3960	3580	4175
	6	3960	3490	4235	2840	2365	3115	2340	1870	2615	4460	3990	4735
	8	4445	3885	4720	3260	2705	3535	2760	2200	3035	4945	4385	5220
225	2	3055	2715	3240	1930	1600	2115	1370	1035	1555	3615	3275	3800
	4	4010	3505	4265	2475	1975	2730	1915	1410	2170	4570	4065	4825
	6	4755	4125	5080	3135	3510	3460	2575	1950	2900	5315	4685	5640
	8	5300	4560	5630	3660	2925	3990	3100	2360	3430	5860	5120	6190
250	2	3900	3900	6465	1245	1250	3810	1785	1785	4350	3360	3360	5925
	4	5050	5050	8410	1750	1755	5110	2290	2290	5650	4510	4510	7870
	6	5645	5645	9700	2410	2420	6470	2950	2950	7010	5105	5105	9160
	8	6150	6150	10795	2875	2875	7520	3415	3415	8060	5610	5610	10255
280	2	4395	4395	7045	1095	1095	3745	1595	1595	4245	3895	3895	6545
	4	5790	5790	9220	1340	1340	4770	1840	1840	5270	5290	5290	8720
	6	6290	6290	10450	2100	2100	6265	2600	2600	6765	5790	5790	9950
	8	6860	6860	11615	2575	2575	7330	3075	3075	7830	6360	6360	11115
315	2	5127	5127	7585	-	-	2890	2890	930	3390	4627	4627	7087
	4	7700	7700	11290	-	-	3423	432	432	4023	7100	7100	10690
	6	8422	8422	12730	325	325	4625	920	920	5225	7822	7822	12130
	8	9040	9040	14007	935	935	5905	1535	1535	6505	8440	8440	13407

Standard design with deep groove ball bearings

Frame Size	Pole Number	Shaft Down						Shaft Up					
		F _{A1}			F _{A2}			F _{A1}			F _{A2}		
		F _R = max		F _R = 0	F _R = max		F _R = 0	F _R = max		F _R = 0	F _R = max		F _R = 0
		F _{X0}	F _{Xmax}		F _{X0}	F _{Xmax}		F _{X0}	F _{Xmax}		F _{X0}	F _{Xmax}	
355	2	9261	9261	11219	-	-	-	-	-	-	8661	8661	10619
	4	9265	9265	14150	740	740	5630	1340	1340	6200	8665	8665	13500
	6	10200	10200	16000	1253	1253	7043	1853	1853	7600	9660	9660	15400
	8	11000	11000	17650	2015	2015	8634	2600	2600	9200	10400	10400	17000
400	2	10948	10948	12600	-	-	-	-	-	-	10348	10348	12000
	4	14512	14512	19473	-	-	3700	-	-	4300	13912	13912	18873
	6	15023	15023	21213	325	325	6518	928	928	7118	14423	14423	20613
	8	15865	15865	22950	1170	1170	8255	1770	1770	8855	15265	15265	22350

Reinforced design with NU cylindrical roller bearing

Frame Size	Pole Number	Shaft Down						Shaft Up					
		F _{A1}			F _{A2}			F _{A1}			F _{A2}		
		F _R = max		F _R = 0	F _R = max		F _R = 0	F _R = max		F _R = 0	F _R = max		F _R = 0
		F _{X0}	F _{Xmax}		F _{X0}	F _{Xmax}		F _{X0}	F _{Xmax}		F _{X0}	F _{Xmax}	
160	2	2445	1850	2725	1900	1310	2185	1900	1310	2185	2445	1850	2725
	4	3240	2515	3625	2450	1730	2835	2450	1730	2835	3240	2515	3625
	6	3775	2895	4240	2940	2065	3410	2940	2065	3410	3775	2895	4240
	8	4275	3265	4735	3350	2340	3810	3350	2340	3810	4275	3265	4735
180	2	2970	2335	3270	2180	1545	2480	2180	1545	2480	2970	2335	3270
	4	3905	3135	4310	2800	2030	3205	2800	2030	3205	3905	3135	4310
	6	4575	3645	5080	3430	2495	3930	3430	2495	3930	4575	3645	5080
	8	5135	4055	5635	2870	3950	4450	2870	3950	4450	5135	4055	5635
200	2	3895	3145	4305	2760	2015	3175	2760	2015	3175	3895	3145	4305
	4	5205	4295	5735	3530	2625	4060	3530	2625	4060	5205	4295	5735
	6	5975	4880	6630	4355	3260	5005	4355	3260	5005	5975	4880	6630
	8	6690	5420	7390	5000	3730	5700	5000	3730	5700	6690	5420	7390
225	2	4535	3680	5055	2850	2000	3370	2850	2000	3370	4535	3680	5055
	4	5905	4605	6565	3805	2505	4470	3805	2505	4470	5905	4605	6565
	6	6930	5410	7750	4755	3235	5570	4755	3235	5570	6930	5410	7750
	8	7720	5970	8610	5520	3770	6410	5520	3770	6410	7720	5970	8610
250	2	5430	4220	6195	3310	2105	4080	3310	2105	4080	5430	4220	6195
	4	7210	5625	8140	4450	2870	5380	4450	2870	5380	7210	5625	8140
	6	8295	6495	9430	5605	3810	6740	5605	3810	6740	8295	6495	9430
	8	9205	7150	10525	6470	4420	7790	6470	4420	7790	9205	7150	10525
280	2	6110	4980	6790	3310	2180	3990	3310	2180	3990	6110	4980	6790
	4	8150	6655	8970	4195	2705	5020	4195	2705	5020	8150	6655	8970
	6	9200	7520	10200	5510	3835	6515	5510	3835	6515	9200	7520	10200
	8	10200	8285	11365	6415	4500	7580	6415	4500	7580	10200	8285	11365
315	2	6165	5248	7087	2468	1547	3390	1968	1051	2890	6665	5748	7587
	4	9765	8070	10990	2495	800	3725	2495	800	3725	9765	8070	10990
	6	10952	9055	12430	3450	1552	7926	3450	1552	4925	10952	9055	12430
	8	12000	9915	13707	4497	2482	6204	4497	2412	6204	12000	9915	13707
355	2	11813	10965	12300	-	-	-	-	-	-	11813	10965	12300
	4	13000	11000	13850	5100	3100	5900	5100	3100	5900	13000	11000	13850
	6	14600	11600	15700	6200	3200	7300	6200	3200	7300	14600	11600	16700
	8	16000	12700	17350	7600	4300	8900	7600	4300	8900	16000	12700	17350
400	2	11813	10965	12300	-	-	-	-	-	-	11813	10965	12300
	4	17871	15364	19173	2698	190	4000	2698	190	4000	17871	15364	19173
	6	19510	16446	20193	5415	2350	6818	5415	2350	6818	19510	16446	20913
	8	21389	18816	22650	7294	4719	8555	7294	4719	8555	21389	18816	22650

11.12. MOTOR PROTECTION

To protect the motor, fuses, thermic relays, thermal magnetic switches and thermal protectors could be used. Fuses protect energy lines (motor, relays, switches etc.) against the short circuit but they are not enough, just themselves, in the case of overloading and over heating. Although it is possible to prevent over current on motor terminals with thermic relays and thermal magnetic switches, in the case of over heating they are not proper solution.

Long-term operating of motor under overload, with unbalanced or low supply voltage may be cause to current flow through stator winding that is more than nominal value, it raises winding temperature over expected and permissible values. To prevent any damaged caused by heating on stator winding thermal motor protectors should be used. They are placed in the motor windings and provide suitable motor thermal protection.

11.12.1. PTC (POSITIVE TEMPERATURE COEFFICIENT) THERMISTORS

PTC thermistors are thermal protectors consisting of semiconductor detectors and using with relays, installed in the motor winding (three in series, one per each phase winding). Their resistance rises suddenly at a certain critical temperature. This sudden resistance increment blocks the PTC current and causing to main circuit switched off.

Where thermistor protection is required to provide both alarm and trip operations, it is necessary to use two sets of thermistors (two thermistors per phase). For alarm operation the temperature should be 20K less than tripping temperature. When it reaches the critical temperature value a warning signal is sent to relay.

PTC thermistors should be chosen according to motor insulation class.

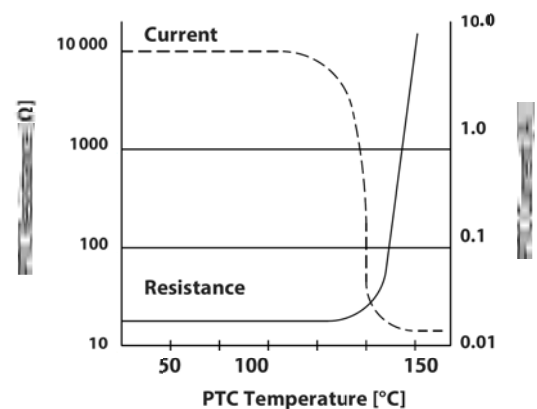

On PTC thermistor can be used on stator windings and the requests must be specified in order with their demand codes. (Demand codes are on page 52.)

11.12.2. PT100

PT100 is a temperature sensor with platinum resistance inside. It has 100Ω resistance at 0°C and the resistance value of platinum changes linearly for even small increment or decrement of temperature. Sensitive and continuous winding temperature measuring is possible through a monitoring display. PT100 can be used both for alarm and trip operations with a relay. It is important to set alarm and tripping temperature values taking into account the insulation class of motor and regular operating temperature.

On request PT100 can be used on stator windings and the requests must be specified in order with their demand codes. (Demand codes are on page 52.)

11.12.3. BIMETAL THERMAL PROTECTORS

The bimetallic thermal protectors are placed in stator windings one per each phase and series connected with the contactor coil. With the increasing motor current, winding temperature rises and when the critical temperature is reached, shape of bimetal layer inside the thermostat change and open the contactor. When their operating temperature decreases, they return to their original shape immediately, let the contactor to close again.

They can be used either as alarm or trip. To use both alarm and trip operation two sets of thermostat must be placed. Bimetallic thermal protectors should be chosen according to motor insulation class and maximum permissible operation temperature for motor windings.

On request bimetal thermal protectors can be used on stator windings and the requests must be specified in order with their demand codes. (Demand codes are on page 52.)

11.13. VOLTAGE AND FREQUENCY

Omega Motors are designed for a rated supply of 400V and frequency of 50Hz. However, motors for any standard supply from 110V to 690V at frequencies of 50Hz or 60Hz may be supplied on request. Any request different than 400V 50Hz supply should be specified in the order. Motors will operate satisfactorily within a voltage band of ±5% of the rated voltage and ±2% of the rated frequency. In case of continuous operation at the extreme voltage limits specified above, the temperature rise limits permitted for various insulation classes may be exceeded by 10K.

When motors are operated at 60Hz, shaft speed increases by 20% compared to 50Hz operation. Based on change of speed all other motor performance values change. Variation of performance values (output power, speed, current and torque) are given at below table. It should be noted that efficiency class may change when these motors are operated at different voltage levels.

Rated Voltage at 50Hz [V]	Supply Voltage at 60Hz [V]	60Hz Performance Values							
		Output Power	Speed	Current	Torque	I_A/I_N	T_A/T_N	T_K/T_N	I_0
230	230	1	1,2	1,00	0,83	0,85	0,75	0,80	0,75
	230*	1	1,2	1,00	0,83	1,10	1,00	1,05	1,00
	230**	1,2	1,2	1,20	1,00	1,00	1,00	0,95	1,03
	240	1	1,2	0,90	0,83	1,03	1,00	1,00	0,85
	255	1	1,2	0,86	0,83	1,15	1,15	1,10	0,92
400	400	1	1,2	1,00	0,83	0,85	0,75	0,80	0,75
	400*	1	1,2	1,00	0,83	1,10	1,00	1,05	1,00
	400**	1,2	1,2	1,20	1,00	1,00	1,00	0,95	1,03
	440	1	1,2	0,90	0,83	1,03	1,00	1,00	0,85
	460	1	1,2	0,86	0,83	1,15	1,15	1,10	0,92
500	480	1	1,2	0,84	0,83	1,25	1,30	1,24	1,02
	500	1	1,2	1,00	0,83	0,85	0,75	0,80	0,75
	500*	1	1,2	1,00	0,83	1,10	1,00	1,05	1,00
	500**	1,2	1,2	1,20	1,00	1,00	1,00	0,95	1,03
	550	1	1,2	0,90	0,83	1,03	1,00	1,00	0,85
600	575	1	1,2	0,86	0,83	1,15	1,15	1,10	0,92
	600	1	1,2	0,84	0,83	1,25	1,30	1,24	1,02

* Special winding for 60Hz, constant power.

** Special winding for 60Hz, constant torque.

I_N : Nominal current

I_A : Locked rotor current

T_K : Breakdown torque

T_N : Nominal torque

T_A : Locked rotor torque

I_0 : No-load current

11.13.1. Motor Starting Methods and End Connections

The starting current of the motors is about 6-8 times of the motor full load current. The excess current drawn, even momentarily, may have unwanted reflections on the grid. In order to reduce these current, the motors can be started in different ways depending on the motor power and application for protecting both the grid and the motor.

Direct Online Starting

The motor is directly connected to the grid and the motor started in this way. It should be kept in mind that the motor will draw high current at the starting and current limitations on the grid should be observed.

Star / Delta Starter

In order for the current to be small while starting, the motor windings are connected in star first and then in delta connection. Thus, the starting current of the motor decrease by %67. It should be kept in mind that when the motor is started in this method, the starting torque will also decrease by %67.

Motor Starting Methods Pole Number	Direct Online 400V (Y Connection)	Direct Online, Y / Δ, Other 400V (Δ Connection)
	2	$P_N \leq 3kW$
4	$P_N \leq 3kW$	$P_N \geq 4kW$
6	$P_N \leq 2,2kW$	$P_N \geq 3kW$
8	$P_N \leq 1,5kW$	$P_N \geq 2,2kW$

The table on the side shows the method to use the terminal connections according to the motor powers.

10.14. PRODUCT CODE

Sample Product Code	3	M	0	S	A	4	E	-	22	M	A	4	0	C	T	0	-	A	0	1	
Positions	1	2	3	4	5	6	7	-	8	9	10	11	12	13	14	15	-	16	17	18	
3 Phase, Totally enclosed, Fan cooled, Induction motor	3	M	0	S														X	0	0	Demand Codes
Frame Material	Aluminium				A								0	0, 1, 2, 3,				Generation Code			
	Cast Iron				G								...	4, 5, 6,							
	Steel				S								9	7, 8, 9							
Efficiency Class <i>One Speed Motors</i>	3E: IE3 efficiency class				3	E								L	Left Hand Side				Terminal Box Position <i>(Viewed from DE side)</i>		
	4E: IE4 efficiency class				4	E								R	Right Hand Side						
Winding Type	1S: Two speed, Dahlander, Constant torque				1	S								T	Top						
	1D: Two speed, Dahlander, Variable torque				1	D								B	Bottom						
<i>Pole-Changing Motors</i>	2S: Two speed, Constant torque				2	S								A	IM B3						
	2D: Two speed, Variable torque				2	D								B	IM B5						
	3S: Three speed, Constant torque				3	S								.	C: IM B35						
	3D: Three speed, Variable torque				3	D								.	D: IM V1						
Frame Size	71											.	E: IM V15								
	80											.	F: IM B9								
	90											.	G: IM B15								
	100											.	H: IM B6								
	112											.	J: IM B7								
	132											.	K: IM B8								
	160											.	L: IM V5								
	180											.	M: IM V6								
	200											.	N: IM V3								
	225											.	Q: IM B14-2		P: IM V8						
	250											.	R: IM V9		S: IM B14						
	280											.	T: IM B34		U: IM V18-2						
	315											.	V: IM V19-2		W: IM B34-2						
	355											.	X: IM B10		Y: IM V18						
	400											.	Z								
												Z	IM V19								
Frame Length	L											L	0				400/690V - Δ/Y, 50Hz				Voltage Connection Frequency
	M											M	1				230/400V - Δ/Y, 50Hz				
	S											S	5				525V - Δ, 50Hz				
Core Length	A, B, C, D, E											A	6				525V - Y, 50Hz				<i>One Speed Motors</i>
												...	A				400/690V - Δ/Y, 60Hz				
												E	B				230/400V - Δ/Y, 60Hz				
Pole Number	2: 2pole, 4: 4pole, 6: 6pole, 8: 8pole											2	E				400V, 50 Hz				<i>Pole-Changing Motors</i>
												...	F				500V, 50 Hz				
												8	H				230V, 50 Hz				
	A: 10pole, B: 12pole, C: 16pole											A	.								
	D: 4/2, E: 8/4, F: 6/4											D	Z				Special Requests				

ORDERING EXAMPLE		Product Code
Motor Type	3 Phase, Totally enclosed induction motor	3M0SA4E - 22MA40CT0 - A01
Frame Material	Aluminium	3M0SA A 4E - 22MA40CT0 - A01
Efficiency Class	IE4 efficiency class	3M0SA 4 E - 22MA40CT0 - A01
Frame Size - Pole Number/Speed	225 M - 4 pole / 1500rpm	3M0SA4E - 22MA40 CT0 - A01
Motor Output Power	45 kW	
Voltage - Connection - Frequency	400/690V - Δ/Y - 50Hz	3M0SA4E - 22MA 40 CT0 - A01
Mounting Arrangement	IM B35 (IM 3001)	3M0SA4E - 22MA40 CT 0 - A01
Terminal Box Position (Viewed from DE side)	On Top	3M0SA4E - 22MA40 CT 0 - A01
Special Demands	Codes from pages 52 and 53	3M0SA4E - 22MA40CT0 - A01

10.15. NAME PLATE

Nominal efficiency values are determined according to IEC 60034-2-1:2014 and efficiency classes are based on IEC 60034-30-1:2014. Label material is aluminium as standard and is located on right hand side (viewed from DE side). Following name plates are only samples. For different name plates and materials please see page 52.

V	Hz	kW	r/min	A	cosφ	Eff Cl.	4/4	3/4	2/4
D/Y 230/400	50	2.2	1445	8.73/5.02	0.73	IE3	86.7	86.9	85.2
D/Y 220/380	50	2.2	1440	8.56/4.96	0.78	IE3	86.7	86.0	84.3
D/Y 240/415	50	2.2	1450	9.14/5.29	0.67	IE3	86.7	85.6	83.9
Y 440	60	2.2	1730	4.15	0.78	IE3	89.5	88.7	87.1
Y 480	60	2.2	1745	4.72	0.63	IE3	89.5	89.3	87.6

Rating plate for frame sizes 71 to 112 is given above.

V	Hz	kW	r/min	A	cosφ	Eff Cl.	4/4	3/4	2/4
D/Y 400/690	50	7.5	2915	14.0/8.14	0.86	IE3	90.1	91.1	91.0
D/Y 380/660	50	7.5	2900	14.4/8.31	0.88	IE3	90.1	89.1	89.0
D 415	50	7.5	2925	14.0/8.14	0.83	IE3	90.1	90.0	89.9
D 440	60	7.5	3475	12.4	0.88	IE3	90.2	89.2	89.1
D 480	60	7.5	3525	14.4	0.81	IE3	90.2	92.1	92.0

Rating plate for aluminum motors, frame sizes from 132 to 225, is given above.

V	Hz	kW	r/min	A	cosφ	Eff Cl.	4/4	3/4	2/4
D/Y 400/690	50	45	1485	79.2/45.9	0.86	IE4	95.4	95.7	95.5
D/Y 380/660	50	45	1485	83.3/48.0	0.86	IE4	95.4	95.7	95.5
D 415	50	45	1485	76.3	0.86	IE4	95.4	95.7	95.5
D 440	60	45	1780	72.0	0.86	IE4	95.4	95.7	95.5
D 480	60	45	1780	66.0	0.86	IE4	95.4	95.7	95.5

Rating plate for cast iron motors, frame sizes from 160 to 225, is given above.

V	Hz	kW	r/min	A	cosφ	Eff Cl.	4/4	3/4	2/4
D/Y 400/690	50	315	1490	543/315	0.87	IE3	96.0	96.2	95.9
D/Y 380/660	50	315	1490	564/325	0.88	IE3	96.0	96.2	95.9
D 415	50	315	1490	537	0.85	IE3	96.0	96.5	96.2
D 440	60	315	1790	487	0.88	IE3	96.2	96.4	96.1
D 480	60	315	1790	469	0.84	IE3	96.2	96.7	96.4

Rating plate for frame sizes 250 to 400 is given above.

- 1 AC Motor phase number
- 2 Product code
- 3 Motor type
- 4 Product serial number
- 5 Mounting arrangement
- 6 IP Protection degree
- 7 Insulation class
- 8 Temperature rise
- 9 Ambient temperature
- 10 Duty type
- 11 Motor weight
- 12 Connection and voltage
- 13 Frequency
- 14 Nominal output power
- 15 Nominal speed
- 16 Nominal current

- 17 Power factor
- 18 Efficiency class according to IEC 60034-30-1
- 19 Efficiency values at 100%, 75% and 50% load
- 20 Bearing, DE side
- 21 Bearing, NDE side
- 22 Recycling and disposal symbol
- 23 QR Code
- 24 Manufacturing date (Week / Year)
- 25 Rating and performance standard
- 26 Grease amount (DE Bearing)
- 27 Grease amount (NDE Bearing)
- 28 Lubrication period
- 29 Service factor

PERFORMANCE VALUES

Standard 3 phase, Squirrel Cage Induction Motors
 IP 55 protection, IC 411 cooling, F class insulation, B temperature rise
 IE3: Premium Efficiency Class (IEC 60034-30-1:2014)

2 Pole, 3000 rpm; 400 V 50 Hz

ALUMINIUM FRAME

STANDARD MOTORS

Output Power kW	Motor Type	Product Code	Speed n rpm	Current I _N A	Torque T _N Nm	Power Factor cosφ	Efficiency			Starting Current Ratio I _s /I _N	Starting Torque Ratio T _A /T _N	Breakdown Torque Ratio T _K /T _N	Moment of Inertia J kgm ²	Weight B3 kg
							4/4	3/4	2/4					
							Load 100%	Load 75%	Load 50%					
0,37	3MAS 71MA2	3MOSA3E-07MA2	2870	1,16	1,23	0,62	73,8	73,4	71,1	4,2	2,2	3,6	0,0004	5
0,55	3MAS 71MB2	3MOSA3E-07MB2	2870	1,42	1,83	0,72	77,8	78,7	75,0	4,9	2,3	3,7	0,0006	6
0,75	3MAS 80MA2	3MOSA3E-08MA2	2875	1,80	2,49	0,75	80,7	80,3	76,5	4,7	2,5	3,2	0,0009	9
1,1	3MAS 80MB2	3MOSA3E-08MB2	2865	2,49	3,67	0,77	82,7	83,1	80,7	4,8	2,4	3,3	0,0011	10
1,5	3MAS 90SA2	3MOSA3E-09SA2	2875	3,17	4,98	0,81	84,2	85,0	84,0	5,6	2,3	3,2	0,0017	13
2,2	3MAS 90LA2	3MOSA3E-09LA2	2885	4,54	7,28	0,82	85,9	86,7	85,3	5,8	2,4	3,6	0,0023	16
3	3MAS 100LA2	3MOSA3E-10LA2	2900	5,81	9,90	0,86	87,1	88,0	86,8	7,0	2,6	3,5	0,0041	22
4	3MAS 112MA2	3MOSA3E-11MA2	2905	7,53	13,1	0,87	88,1	89,0	88,0	7,3	2,6	3,5	0,0066	26
5,5	3MAS 132SA2	3MOSA3E-13SA2	2915	10,6	18,0	0,84	89,2	90,1	89,5	6,2	2,6	3,0	0,0148	40
7,5	3MAS 132SB2	3MOSA3E-13SB2	2915	14,0	24,6	0,86	90,1	91,1	91,0	6,4	2,6	3,0	0,0182	46
11	3MAS 160MA2	3MOSA3E-16MA2	2940	20,0	35,7	0,87	91,2	91,9	91,6	6,4	2,4	2,9	0,0388	75
15	3MAS 160MB2	3MOSA3E-16MB2	2930	26,6	48,9	0,89	91,9	92,8	92,7	6,5	2,5	3,0	0,0473	87
18,5	3MAS 160LA2	3MOSA3E-16LA2	2940	32,5	60,1	0,89	92,4	93,3	93,4	6,5	2,5	3,1	0,0563	99
22	3MAS 180MA2	3MOSA3E-18MA2	2960	37,9	71,0	0,90	92,7	93,4	93,5	7,1	2,3	2,8	0,0926	127
30	3MAS 200LA2	3MOSA3E-20LA2	2965	52,2	96,6	0,89	93,3	93,7	93,2	7,4	2,6	2,9	0,170	202
37	3MAS 200LB2	3MOSA3E-20LB2	2965	63,8	119	0,89	93,7	94,2	94,0	7,5	2,5	3,0	0,187	216
45	3MAS 225MA2	3MOSA3E-22MA2	2975	76,4	144	0,91	94,0	94,3	93,9	8,1	2,6	3,3	0,332	256
55	3MAS 250MA2	3MOSA3E-25MA2	2975	92,5	177	0,91	94,3	94,7	94,4	7,8	2,5	3,0	0,474	397

COMPACT MOTORS

Output Power kW	Motor Type	Product Code	Speed n rpm	Current I _N A	Torque T _N Nm	Power Factor cosφ	Efficiency			Starting Current Ratio I _s /I _N	Starting Torque Ratio T _A /T _N	Breakdown Torque Ratio T _K /T _N	Moment of Inertia J kgm ²	Weight B3 kg
							4/4	3/4	2/4					
							Load 100%	Load 75%	Load 50%					
1,5	3MAS 80MK2	3MOSA3E-08MK2	2865	3,29	5,00	0,78	84,2	84,7	83,0	5,7	2,9	3,7	0,0014	11
3	3MAS 90LK2	3MOSA3E-09LK2	2895	6,11	9,90	0,81	87,1	87,6	86,3	6,6	2,6	3,2	0,0030	20
4	3MAS 100LK2	3MOSA3E-10LK2	2905	7,67	13,1	0,85	88,1	88,9	88,0	7,4	2,7	3,6	0,0049	26
5,5	3MAS 112MK2	3MOSA3E-11MK2	2905	9,90	18,1	0,90	89,2	90,3	90,2	7,1	2,7	3,5	0,0087	34
11	3MAS 132MK2	3MOSA3E-13MK2	2935	19,8	35,8	0,88	91,2	92,6	93,2	6,6	2,6	3,1	0,0239	58
22	3MAS 160LK2	3MOSA3E-16LK2	2940	38,3	71,5	0,89	92,7	93,7	94,0	6,8	2,7	3,2	0,0648	111
30	3MAS 180LK2	3MOSA3E-18LK2	2960	49,5	96,8	0,94	93,3	94,2	94,4	7,4	2,5	3,1	0,118	160
45	3MAS 200LK2	3MOSA3E-20LK2	2965	76,9	145	0,90	94,0	94,4	94,2	7,9	2,7	3,3	0,219	240
55	3MAS 225MK2	3MOSA3E-22MK2	2975	92,5	177	0,91	94,3	94,8	94,7	8,0	2,6	3,2	0,392	297
75	3MAS 250MK2	3MOSA3E-25MK2	2975	124	241	0,92	94,7	95,3	95,4	7,9	2,6	3,1	0,584	412
90	3MAS 250ML2	3MOSA3E-25ML2	2970	150	289	0,91	95,0	95,4	95,5	7,6	2,2	3,1	0,643	433

Efficiency values are determined according to IEC 60034-2-1:2014. (By the summation of all separate losses, including additional load loss)

IE3

PERFORMANCE VALUES

Standard 3 phase, Squirrel Cage Induction Motors
 IP 55 protection, IC 411 cooling, F class insulation, B temperature rise
 IE3: Premium Efficiency Class (IEC 60034-30-1:2014)

2 Pole, 3000 rpm; 400 V 50 Hz

CAST IRON FRAME

STANDARD MOTORS

Output Power kW	Motor Type	Product Code	Speed n rpm	Current I _N A	Torque T _N Nm	Power Factor cosφ	Efficiency			Starting Current Ratio I _s /I _N	Starting Torque Ratio T _s /T _N	Breakdown Torque Ratio T _K /T _N	Moment of Inertia J kgm ²	Weight B3 kg
							4/4 Load 100%	3/4 Load 75%	2/4 Load 50%					
11	3MGS 160MA2	3M0SG3E- 16MA2	2940	20,0	35,7	0,87	91,2	91,9	91,6	6,4	2,4	2,9	0,0388	106
15	3MGS 160MB2	3M0SG3E- 16MB2	2930	26,6	48,9	0,89	91,9	92,8	92,7	6,5	2,5	3,0	0,0473	118
18,5	3MGS 160LA2	3M0SG3E- 16LA2	2940	32,5	60,1	0,89	92,4	93,3	93,4	6,5	2,5	3,1	0,0563	129
22	3MGS 180MA2	3M0SG3E- 18MA2	2960	37,9	71,0	0,90	92,7	93,4	93,5	7,1	2,3	2,8	0,0926	167
30	3MGS 200LA2	3M0SG3E- 20LA2	2965	52,2	96,6	0,89	93,3	93,7	93,2	7,4	2,6	2,9	0,170	244
37	3MGS 200LB2	3M0SG3E- 20LB2	2965	63,8	119	0,89	93,7	94,2	94,0	7,5	2,6	3,0	0,187	261
45	3MGS 225MA2	3M0SG3E- 22MA2	2975	76,4	144	0,91	94,0	94,3	93,9	8,1	2,6	3,3	0,332	315
55	3MGS 250MA2	3M0SG3E- 25MA2	2975	92,5	177	0,91	94,3	94,7	94,4	7,8	2,5	3,0	0,474	418
75	3MGS 280SA2	3M0SG3E- 28SA2	2985	129	240	0,89	94,7	94,6	93,8	8,7	2,7	3,4	0,830	584
90	3MGS 280MA2	3M0SG3E- 28MA2	2985	153	288	0,89	95,0	95,1	94,6	8,8	2,7	3,3	0,916	638
110	3MGS 315SA2	3M0SG3E- 31SA2	2985	183	352	0,91	95,2	95,0	94,2	8,2	2,2	3,4	1,70	858
132	3MGS 315MA2	3M0SG3E- 31MA2	2985	218	422	0,92	95,4	95,3	94,7	8,2	2,2	3,2	1,86	908
160	3MGS 315MB2	3M0SG3E- 31MB2	2985	264	512	0,92	95,6	95,8	95,3	8,3	2,3	3,5	2,06	966
185	3MGS 315MC2	3M0SG3E- 31MC2	2980	306	593	0,91	95,7	95,9	95,5	8,3	2,4	3,3	2,31	951
200	3MGS 315MD2	3M0SG3E- 31MD2	2985	330	640	0,91	95,8	96,0	95,7	8,4	2,3	3,6	2,31	1041
250	3MGS 355MA2	3M0SG3E- 35MA2	2985	418	800	0,90	95,8	95,7	95,2	8,4	2,3	3,5	3,81	1383
315	3MGS 355MB2	3M0SG3E- 35MB2	2985	518	1008	0,92	95,8	95,9	95,5	8,6	2,3	3,5	4,63	1547
355	3MGS 355MC2	3M0SG3E- 35MC2	2985	583	1136	0,92	95,8	96,0	95,6	8,7	2,5	3,0	5,72	1612
400	3MGS 355LA2	3M0SG3E- 35LA2	2985	643	1280	0,94	95,8	95,9	95,6	9,0	2,5	3,8	5,74	1780
450	3MGS 355LB2	3M0SG3E- 35LB2	2985	721	1440	0,94	95,8	96,3	96,0	8,9	2,4	4,2	7,21	2057
500	3MGS 355LC2	3M0SG3E- 35LC2	2985	810	1600	0,93	95,8	95,8	95,3	9,8	2,7	3,0	7,97	2208
560	3MGS 400LA2	3M0SG3E- 40LA2	2985	919	1791	0,90	95,8	95,9	95,5	7,8	2,1	2,8	7,9	3003
630	3MGS 400LB2	3M0SG3E- 40LB2	2985	1043	2015	0,91	95,8	95,7	94,9	7,7	2,0	3,4	8,9	3158
710	3MGS 400LC2	3M0SG3E- 40LC2	2985	1176	2271	0,91	95,8	95,6	94,6	7,4	2,0	3,1	8,8	3304

COMPACT MOTORS

Output Power kW	Motor Type	Product Code	Speed n rpm	Current I _N A	Torque T _N Nm	Power Factor cosφ	Efficiency			Starting Current Ratio I _s /I _N	Starting Torque Ratio T _s /T _N	Breakdown Torque Ratio T _K /T _N	Moment of Inertia J kgm ²	Weight B3 kg
							4/4 Load 100%	3/4 Load 75%	2/4 Load 50%					
22	3MGS 160LK2	3M0SG3E- 16LK2	2940	38,3	71,5	0,89	92,7	93,7	94,0	6,8	2,7	3,2	0,0648	141
30	3MGS 180LK2	3M0SG3E- 18LK2	2960	49,5	96,8	0,94	93,3	94,2	94,4	7,4	2,5	3,1	0,118	196
45	3MGS 200LK2	3M0SG3E- 20LK2	2965	76,9	145	0,90	94,0	94,4	94,2	7,9	2,7	3,3	0,219	287
55	3MGS 225MK2	3M0SG3E- 22MK2	2975	92,5	177	0,91	94,3	94,8	94,7	8,0	2,6	3,2	0,392	359
75	3MGS 250MK2	3M0SG3E- 25MK2	2975	124	241	0,92	94,7	95,3	95,4	7,9	2,6	3,1	0,584	474
90	3MGS 250ML2	3M0SG3E- 25ML2	2970	150	289	0,91	95,0	95,4	95,5	7,6	2,2	3,1	0,643	501
110	3MGS 280MK2	3M0SG3E- 28MK2	2985	187	352	0,89	95,2	95,4	95,0	8,8	2,7	3,4	1,07	692
132	3MGS 280ML2	3M0SG3E- 28ML2	2980	226	423	0,89	95,4	95,7	95,5	8,7	2,7	3,6	1,19	685
250	3MGS 315LK2	3M0SG3E- 31LK2	2980	413	801	0,91	95,8	96,1	95,9	8,4	2,2	3,4	3,22	1310
315	3MGS 315LL2	3M0SG3E- 31LL2	2980	516	1009	0,92	95,8	96,0	95,9	7,6	2,3	3,4	3,22	1366

Efficiency values are determined according to IEC 60034-2-1:2014. (By the summation of all separate losses, including additional load loss)

PERFORMANCE VALUES

Standard 3 phase, Squirrel Cage Induction Motors
 IP 55 protection, IC 411 cooling, F class insulation, B temperature rise
 IE3: Premium Efficiency Class (IEC 60034-30-1:2014)

4 Pole, 1500 rpm; 400 V 50 Hz

ALUMINIUM FRAME

STANDARD MOTORS

Output Power kW	Motor Type	Product Code	Speed n rpm	Current I _N A	Torque T _N Nm	Power Factor cosφ	Efficiency			Starting Current Ratio I _s /I _N	Starting Torque Ratio T _s /T _N	Breakdown Torque Ratio T _K /T _N	Moment of Inertia J kgm ²	Weight B3 kg
							4/4 Load	3/4 Load	2/4 Load					
							100%	75%	50%					
0,25	3MAS 71MA4	3MOSA3E-07MA4	1430	0,78	1,67	0,63	73,5	72,9	70,1	3,8	2,5	3,0	0,0007	6
0,37	3MAS 71MB4	3MOSA3E-07MB4	1430	1,01	2,47	0,68	77,3	77,1	75,3	4,0	2,5	2,8	0,0011	7
0,55	3MAS 80MA4	3MOSA3E-08MA4	1430	1,59	3,67	0,62	80,8	80,1	76,4	4,6	2,9	3,3	0,0017	10
0,75	3MAS 80MB4	3MOSA3E-08MB4	1435	2,01	4,99	0,65	82,5	82,3	79,0	5,0	2,9	3,1	0,0021	11
1,1	3MAS 90SA4	3MOSA3E-09SA4	1440	2,62	7,29	0,72	84,1	83,9	81,2	6,1	3,0	3,5	0,0036	14
1,5	3MAS 90LA4	3MOSA3E-09LA4	1435	3,50	10,0	0,73	85,3	85,5	83,4	5,9	3,0	3,4	0,0045	16
2,2	3MAS 100LA4	3MOSA3E-10LA4	1445	5,02	14,5	0,73	86,7	86,9	85,2	6,3	2,8	3,5	0,0069	22
3	3MAS 100LB4	3MOSA3E-10LB4	1445	6,50	19,8	0,76	87,7	88,2	87,2	6,5	2,9	3,6	0,0089	25
4	3MAS 112MA4	3MOSA3E-11MA4	1445	8,46	26,4	0,77	88,6	89,3	88,5	6,8	3,3	3,5	0,0133	31
5,5	3MAS 132SA4	3MOSA3E-13SA4	1455	11,3	36,1	0,78	89,6	90,7	90,5	6,0	2,4	2,9	0,0282	43
7,5	3MAS 132MA4	3MOSA3E-13MA4	1460	15,4	49,1	0,78	90,4	90,9	90,5	6,3	2,5	3,0	0,0365	53
11	3MAS 160MA4	3MOSA3E-16MA4	1470	21,7	71,5	0,80	91,4	92,0	91,6	6,8	2,8	3,1	0,0778	85
15	3MAS 160LA4	3MOSA3E-16LA4	1470	29,4	97,4	0,80	92,1	92,7	92,4	6,9	2,8	3,2	0,102	105
18,5	3MAS 180MA4	3MOSA3E-18MA4	1475	36,0	120	0,80	92,6	93,5	93,6	6,2	2,4	2,7	0,156	127
22	3MAS 180LA4	3MOSA3E-18LA4	1470	42,2	143	0,81	93,0	93,9	94,0	6,5	2,6	2,9	0,179	141
30	3MAS 200LA4	3MOSA3E-20LA4	1475	53,3	194	0,87	93,6	94,4	94,5	6,3	2,3	2,6	0,308	207
37	3MAS 225SA4	3MOSA3E-22SA4	1480	66,6	239	0,85	93,9	94,4	94,2	7,1	2,5	2,9	0,468	241
45	3MAS 225MA4	3MOSA3E-22MA4	1480	79,6	290	0,87	94,2	94,8	94,9	7,0	2,6	2,8	0,542	267
55	3MAS 250MA4	3MOSA3E-25MA4	1485	97,5	354	0,86	94,6	95,0	94,8	7,5	2,7	2,9	0,903	445

COMPACT MOTORS

Output Power kW	Motor Type	Product Code	Speed n rpm	Current I _N A	Torque T _N Nm	Power Factor cosφ	Efficiency			Starting Current Ratio I _s /I _N	Starting Torque Ratio T _s /T _N	Breakdown Torque Ratio T _K /T _N	Moment of Inertia J kgm ²	Weight B3 kg
							4/4 Load	3/4 Load	2/4 Load					
							100%	75%	50%					
1,1	3MAS 80MK4	3MOSA3E-08MK4	1435	2,67	7,32	0,71	84,1	84,7	83,7	5,4	2,1	3,0	0,0030	16
2,2	3MAS 90LK4	3MOSA3E-09LK4	1440	4,91	14,6	0,76	85,6	86,1	84,9	6,7	2,9	3,9	0,0060	24
4	3MAS 100LK4	3MOSA3E-10LK4	1445	5,03	26,4	0,75	88,6	89,1	87,9	7,2	2,7	3,9	0,0124	40
5,5	3MAS 112MK4	3MOSA3E-11MK4	1445	12,2	36,3	0,73	89,6	90,2	89,1	6,4	2,8	3,7	0,0166	37
10*	3MAS 132MK4	3MOSA3E-13MK4	1460	20,4	65,4	0,78	91,2	91,8	91,4	7,4	3,1	3,7	0,0483	70
18,5	3MAS 160LK4	3MOSA3E-16LK4	1470	35,4	120	0,81	92,6	93,3	93,2	7,0	2,9	3,1	0,133	128
30	3MAS 180LK4	3MOSA3E-18LK4	1470	56,8	195	0,82	93,6	94,5	94,6	6,6	2,8	3,1	0,227	177
37	3MAS 200LK4	3MOSA3E-20LK4	1475	64,5	240	0,88	93,9	94,8	95,1	6,4	2,3	2,7	0,364	217
45	3MAS 200LL4	3MOSA3E-20LL4	1475	80,3	291	0,86	94,2	94,8	94,9	7,0	2,2	3,1	0,432	246
55	3MAS 225MK4	3MOSA3E-22MK4	1480	98,3	355	0,85	94,6	95,3	95,4	7,2	2,6	2,9	0,615	293
75	3MAS 250MK4	3MOSA3E-25MK4	1485	132	482	0,86	95,0	95,4	95,2	7,7	2,7	3,0	1,17	402

* The 132MK4 motor, rated at 10kW with a service factor of 1.10, handles a load of 11kW.

Efficiency values are determined according to IEC 60034-2-1:2014. (By the summation of all separate losses, including additional load loss)

IE3

PERFORMANCE VALUES

Standard 3 phase, Squirrel Cage Induction Motors
 IP 55 protection, IC 411 cooling, F class insulation, B temperature rise
 IE3: Premium Efficiency Class (IEC 60034-30-1:2014)

4 Pole, 1500 rpm; 400 V 50 Hz

CAST IRON FRAME

STANDARD MOTORS

Output Power kW	Motor Type	Product Code	Speed n rpm	Current I _N A	Torque T _N Nm	Power Factor cosφ	Efficiency			Starting Current Ratio I _s / I _N	Starting Torque Ratio T _s / T _N	Breakdown Torque Ratio T _k / T _N	Moment of Inertia J kgm ²	Weight B3 kg
							4/4 Load 100%	3/4 Load 75%	2/4 Load 50%					
11	3MGS 160MA4	3M0SG3E-16MA4	1470	21,7	71,5	0,80	91,4	92,0	91,6	6,8	2,8	3,1	0,0778	116
15	3MGS 160LA4	3M0SG3E-16LA4	1470	29,4	97,4	0,80	92,1	92,7	92,4	6,9	2,8	3,2	0,102	138
18,5	3MGS 180MA4	3M0SG3E-18MA4	1475	36,0	120	0,80	92,6	93,5	93,6	6,2	2,4	2,7	0,156	167
22	3MGS 180LA4	3M0SG3E-18LA4	1470	42,2	143	0,81	93,0	93,9	94,0	6,5	2,6	2,9	0,179	187
30	3MGS 200LA4	3M0SG3E-20LA4	1475	53,3	194	0,87	93,6	94,4	94,5	6,3	2,3	2,6	0,308	241
37	3MGS 225SA4	3M0SG3E-22SA4	1480	66,6	239	0,85	93,9	94,4	94,2	7,1	2,5	2,9	0,468	300
45	3MGS 225MA4	3M0SG3E-22MA4	1480	79,6	290	0,87	94,2	94,8	94,9	7,0	2,6	2,8	0,542	327
55	3MGS 250MA4	3M0SG3E-25MA4	1485	97,5	354	0,86	94,6	95,0	94,8	7,5	2,7	2,9	0,903	439
75	3MGS 280SA4	3M0SG3E-28SA4	1490	136	481	0,84	95,0	95,4	95,1	6,7	2,5	2,9	1,55	607
90	3MGS 280MA4	3M0SG3E-28MA4	1485	161	579	0,85	95,2	95,6	95,5	6,9	2,6	2,9	1,75	649
110	3MGS 315SA4	3M0SG3E-31SA4	1490	194	705	0,86	95,4	95,5	95,0	7,9	2,6	3,4	3,29	901
132	3MGS 315MA4	3M0SG3E-31MA4	1490	232	846	0,86	95,6	95,8	95,3	8,0	2,6	3,3	3,61	942
160	3MGS 315MB4	3M0SG3E-31MB4	1490	276	1025	0,87	95,8	96,0	95,9	8,0	2,6	3,2	4,10	974
185	3MGS 315MC4	3M0SG3E-31MC4	1490	319	1186	0,87	95,9	96,1	95,6	8,3	2,7	3,5	4,73	1056
200	3MGS 315MD4	3M0SG3E-31MD4	1490	345	1282	0,87	96,0	96,3	96,1	8,2	2,6	3,3	4,73	1098
250	3MGS 355MA4	3M0SG3E-35MA4	1490	442	1602	0,85	96,0	96,2	96,0	7,9	2,3	3,3	6,66	1434
315	3MGS 355MB4	3M0SG3E-35MB4	1490	543	2019	0,87	96,0	96,2	95,9	7,8	2,3	3,2	8,15	1604
355	3MGS 355MC4	3M0SG3E-35MC4	1490	611	2275	0,87	96,0	96,3	96,2	8,0	2,2	3,2	9,44	1749
400	3MGS 355LA4	3M0SG3E-35LA4	1490	703	2564	0,86	96,0	96,1	95,9	7,6	2,0	3,2	10,6	1891
450	3MGS 355LB4	3M0SG3E-35LB4	1490	789	2884	0,86	96,0	96,1	95,9	8,6	2,4	3,2	11,7	2014
500	3MGS 355LC4	3M0SG3E-35LC4	1490	868	3204	0,87	96,0	96,2	95,9	8,5	2,3	3,3	13,0	2151
560	3MGS 355LD4	3M0SG3E-35LD4	1490	952	3589	0,88	96,0	96,3	96,1	8,4	2,3	3,3	14,5	2334
560	3MGS 400LA4	3M0SG3E-40LA4	1490	968	3588	0,87	96,0	96,1	95,6	7,9	2,0	2,9	15,3	3050
630	3MGS 400LB4	3M0SG3E-40LB4	1490	1076	4038	0,88	96,0	96,1	95,6	8,3	2,4	3,0	16,8	3202
710	3MGS 400LC4	3M0SG3E-40LC4	1490	1213	4550	0,88	96,0	96,0	95,7	8,5	2,3	3,0	17,8	3334

COMPACT MOTORS

Output Power kW	Motor Type	Product Code	Speed n rpm	Current I _N A	Torque T _N Nm	Power Factor cosφ	Efficiency			Starting Current Ratio I _s / I _N	Starting Torque Ratio T _s / T _N	Breakdown Torque Ratio T _k / T _N	Moment of Inertia J kgm ²	Weight B3 kg
							4/4 Load 100%	3/4 Load 75%	2/4 Load 50%					
18,5	3MGS 160LK4	3M0SG3E-16LK4	1470	35,4	120	0,81	92,6	93,3	93,2	7,0	2,9	3,1	0,133	162
30	3MGS 180LK4	3M0SG3E-18LK4	1470	56,8	195	0,82	93,6	94,5	94,6	6,6	2,8	3,1	0,227	218
37	3MGS 200LK4	3M0SG3E-20LK4	1475	64,5	240	0,88	93,9	94,8	95,1	6,4	2,3	2,7	0,364	254
45	3MGS 200LL4	3M0SG3E-20LL4	1475	80,3	291	0,86	94,2	94,8	94,9	7,0	2,2	3,1	0,432	295
55	3MGS 225MK4	3M0SG3E-22MK4	1480	98,3	355	0,85	94,6	95,3	95,4	7,2	2,6	2,9	0,615	347
75	3MGS 250MK4	3M0SG3E-25MK4	1485	132	482	0,86	95,0	95,4	95,2	7,7	2,7	3,0	1,17	512
110	3MGS 280MK4	3M0SG3E-28MK4	1490	196	705	0,85	95,4	95,7	95,4	7,5	2,8	3,1	2,22	736
132	3MGS 280ML4	3M0SG3E-28ML4	1490	233	846	0,86	95,6	95,7	95,6	7,2	2,6	2,7	2,55	801
250	3MGS 315MK4	3M0SG3E-31MK4	1490	432	1602	0,87	96,0	96,2	95,9	8,8	2,8	3,6	6,10	1280
315	3MGS 315LL4	3M0SG3E-31LL4	1490	532	2019	0,89	96,0	96,3	96,3	7,6	3,2	2,7	6,99	1407

Efficiency values are determined according to IEC 60034-2-1:2014. (By the summation of all separate losses, including additional load loss)

PERFORMANCE VALUES

Standard 3 phase, Squirrel Cage Induction Motors
 IP 55 protection, IC 411 cooling, F class insulation, B temperature rise
 IE3: Premium Efficiency Class (IEC 60034-30-1:2014)

6 Pole, 1000 rpm; 400 V 50 Hz

ALUMINIUM FRAME

STANDARD MOTORS

Output Power kW	Motor Type	Product Code	Speed n rpm	Current I _N A	Torque T _N Nm	Power Factor cosφ	Efficiency			Starting Current Ratio I _s /I _N	Starting Torque Ratio T _s /T _N	Breakdown Torque Ratio T _K /T _N	Moment of Inertia J kgm ²	Weight B3 kg
							4/4 Load	3/4 Load	2/4 Load					
							100%	75%	50%					
0,18	3MAS 71MA6	3M0SA3E-07MA6	925	0,66	1,86	0,62	63,9	64,5	62,1	3,4	2,0	2,3	0,0011	7
0,25	3MAS 71MB6	3M0SA3E-07MB6	925	0,85	2,28	0,62	68,6	69,0	65,3	3,4	2,2	2,5	0,0017	8
0,37	3MAS 80MA6	3M0SA3E-08MA6	930	1,15	3,80	0,63	73,5	74,0	73,3	3,7	2,0	2,5	0,0029	10
0,55	3MAS 80MB6	3M0SA3E-08MB6	930	1,63	5,64	0,63	77,2	77,5	73,3	4,3	2,1	2,7	0,0036	12
0,75	3MAS 90SA6	3M0SA3E-09SA6	940	2,18	7,62	0,63	78,9	78,5	76,1	4,6	2,4	3,0	0,0047	14
1,1	3MAS 90LA6	3M0SA3E-09LA6	950	3,22	11,1	0,62	81,0	79,8	76,3	4,7	2,9	3,5	0,0057	17
1,5	3MAS 100LA6	3M0SA3E-10LA6	955	4,10	15,0	0,64	82,5	82,9	82,3	5,0	2,3	3,0	0,0073	21
2,2	3MAS 112MA6	3M0SA3E-11MA6	955	5,80	21,9	0,65	84,3	85,3	84,2	5,4	2,8	3,3	0,0143	33
3	3MAS 132SA6	3M0SA3E-13SA6	970	7,72	29,5	0,66	85,6	85,5	83,0	5,5	2,3	3,3	0,0276	36
4	3MAS 132MA6	3M0SA3E-13MA6	970	9,18	39,4	0,72	86,8	87,5	86,7	6,8	2,8	4,0	0,0368	45
5,5	3MAS 132MB6	3M0SA3E-13MB6	970	12,8	54,1	0,70	88,0	88,3	87,2	6,7	2,8	3,9	0,0473	54
7,5	3MAS 160MA6	3M0SA3E-16MA6	970	16,8	73,8	0,72	89,1	89,5	88,3	6,2	2,3	2,8	0,0793	71
11	3MAS 160LA6	3M0SA3E-16LA6	975	23,0	108	0,77	90,3	90,8	90,3	6,7	2,5	3,1	0,115	92
15	3MAS 180LA6	3M0SA3E-18LA6	975	30,6	147	0,78	91,2	92,2	92,3	6,1	2,3	2,9	0,185	127
18,5	3MAS 200LA6	3M0SA3E-20LA6	980	37,1	180	0,78	91,7	92,4	92,3	5,3	1,9	2,2	0,321	168
22	3MAS 200LB6	3M0SA3E-20LB6	980	43,7	214	0,79	92,2	93,0	92,9	6,0	2,3	2,7	0,377	184
30	3MAS 225MA6	3M0SA3E-22MA6	985	60,9	291	0,77	92,9	93,3	93,1	6,3	2,4	2,8	0,591	241
37	3MAS 250MA6	3M0SA3E-25MA6	990	74,3	357	0,77	93,3	93,6	92,9	7,2	2,7	3,2	0,934	381

COMPACT MOTORS

Output Power kW	Motor Type	Product Code	Speed n rpm	Current I _N A	Torque T _N Nm	Power Factor cosφ	Efficiency			Starting Current Ratio I _s /I _N	Starting Torque Ratio T _s /T _N	Breakdown Torque Ratio T _K /T _N	Moment of Inertia J kgm ²	Weight B3 kg
							4/4 Load	3/4 Load	2/4 Load					
							100%	75%	50%					
30	3MAS 200LK6	3M0SA3E-20LK6	985	60,4	281	0,77	92,9	93,5	93,1	5,8	2,2	2,6	0,499	220
37	3MAS 225MK6	3M0SA3E-22MK6	985	72,8	359	0,79	93,3	94,0	93,9	6,5	2,5	2,9	0,728	274
45	3MAS 250MK6	3M0SA3E-25MK6	985	86,0	436	0,81	93,7	94,3	94,2	7,4	2,7	3,3	1,14	363

Efficiency values are determined according to IEC 60034-2-1:2014. (By the summation of all separate losses, including additional load loss)

IE3

PERFORMANCE VALUES

Standard 3 phase, Squirrel Cage Induction Motors
 IP 55 protection, IC 411 cooling, F class insulation, B temperature rise
 IE3: Premium Efficiency Class (IEC 60034-30-1:2014)

6 Pole, 1000 rpm; 400 V 50 Hz

CAST IRON FRAME

STANDARD MOTORS

Output Power kW	Motor Type	Product Code	Speed n rpm	Current I _N A	Torque T _N Nm	Power Factor cosφ	Efficiency			Starting Current Ratio I _s / I _N	Starting Torque Ratio T _A / T _N	Breakdown Torque Ratio T _K / T _N	Moment of Inertia J kgm ²	Weight B3 kg
							4/4 Load 100%	3/4 Load 75%	2/4 Load 50%					
7,5	3MGS 160MA6	3M0SG3E- 16MA6	970	16,8	73,8	0,72	89,1	89,5	88,3	6,2	2,3	2,8	0,0793	101
11	3MGS 160LA6	3M0SG3E- 16LA6	975	23,0	108	0,77	90,3	90,8	90,3	6,7	2,5	3,1	0,115	127
15	3MGS 180LA6	3M0SG3E- 18LA6	975	30,6	147	0,78	91,2	92,2	92,3	6,1	2,3	2,9	0,185	170
18,5	3MGS 200LA6	3M0SG3E- 20LA6	980	37,1	180	0,78	91,7	92,4	92,3	5,3	1,9	2,2	0,321	211
22	3MGS 200LB6	3M0SG3E- 20LB6	980	43,7	214	0,79	92,2	93,0	92,9	6,0	2,3	2,7	0,377	228
30	3MGS 225MA6	3M0SG3E- 22MA6	985	60,9	291	0,77	92,9	93,3	93,1	6,3	2,4	2,8	0,591	312
37	3MGS 250MA6	3M0SG3E- 25MA6	990	74,3	357	0,77	93,3	93,6	92,9	7,2	2,7	3,2	0,934	394
45	3MGS 280SA6	3M0SG3E- 28SA6	990	90,4	434	0,77	93,7	94,1	93,8	6,7	2,5	2,8	1,49	524
55	3MGS 280MA6	3M0SG3E- 28MA6	990	107	531	0,79	94,1	94,5	94,2	6,7	2,6	2,8	1,82	574
75	3MGS 315SA6	3M0SG3E- 31SA6	990	139	723	0,82	94,6	95,0	94,9	5,7	2,0	2,2	2,99	782
90	3MGS 315MA6	3M0SG3E- 31MA6	990	162	868	0,84	94,9	95,3	95,2	6,1	2,3	2,5	3,47	897
110	3MGS 315MB6	3M0SG3E- 31MB6	990	199	1061	0,84	95,1	95,7	95,8	6,3	2,4	2,6	4,27	979
132	3MGS 315MC6	3M0SG3E- 31MC6	990	234	1273	0,85	95,4	96,0	96,2	6,1	2,3	2,4	5,21	1079
160	3MGS 355MA6	3M0SG3E- 35MA6	990	289	1543	0,84	95,6	95,9	95,7	7,5	2,5	2,8	7,58	1364
200	3MGS 355MB6	3M0SG3E- 35MB6	990	359	1929	0,84	95,8	96,1	96,0	7,7	2,5	2,9	9,25	1520
250	3MGS 355MC6	3M0SG3E- 35MC6	990	442	2411	0,85	95,8	96,1	96,0	7,6	2,4	2,8	10,6	1556
315	3MGS 355LA6	3M0SG3E- 35LA6	990	551	3038	0,86	95,8	96,4	96,3	7,7	2,4	2,8	13,1	1901
355	3MGS 355LB6	3M0SG3E- 35LB6	990	622	3424	0,86	95,8	96,3	96,4	7,9	2,6	3,0	14,8	2064
400	3MGS 355LC6	3M0SG3E- 35LC6	990	699	3858	0,86	95,8	96,2	96,4	7,9	2,5	2,9	16,2	2195
400	3MGS 400LA6	3M0SG3E- 40LA6	990	699	3858	0,86	95,8	95,9	95,3	7,9	2,5	3,0	17,8	2775
450	3MGS 400LB6	3M0SG3E- 40LB6	990	779	4341	0,87	95,8	95,9	95,4	8,0	2,6	3,2	20,1	2856
500	3MGS 400LC6	3M0SG3E- 40LC6	990	856	4823	0,88	95,8	95,7	95,3	8,0	2,7	3,0	21,6	2998
560	3MGS 400LD6	3M0SG3E- 40LD6	990	948	5402	0,89	95,8	95,8	95,4	8,0	2,7	3,1	23,3	3101

COMPACT MOTORS

Output Power kW	Motor Type	Product Code	Speed n rpm	Current I _N A	Torque T _N Nm	Power Factor cosφ	Efficiency			Starting Current Ratio I _s / I _N	Starting Torque Ratio T _A / T _N	Breakdown Torque Ratio T _K / T _N	Moment of Inertia J kgm ²	Weight B3 kg
							4/4 Load 100%	3/4 Load 75%	2/4 Load 50%					
30	3MGS 200LK6	3M0SG3E- 20LK6	985	60,4	281	0,77	92,9	93,5	93,1	5,8	2,2	2,6	0,499	268
37	3MGS 225MK6	3M0SG3E- 22MK6	985	72,8	359	0,79	93,3	94,0	93,9	6,5	2,5	2,9	0,728	350
45	3MGS 250MK6	3M0SG3E- 25MK6	985	86,0	436	0,81	93,7	94,3	94,2	7,4	2,7	3,3	1,14	440
75	3MGS 280MK6	3M0SG3E- 28MK6	985	146	727	0,78	94,6	95,3	95,2	6,6	2,6	2,9	2,17	627
160	3MGS 315MK6	3M0SG3E- 31MK6	990	283	1543	0,85	95,6	96,1	96,2	6,4	2,2	2,4	7,13	1280
200	3MGS 315LL6	3M0SG3E- 31LL6	993	363	1922	0,83	95,8	96,1	96,0	8,1	2,2	2,8	8,72	1460

Efficiency values are determined according to IEC 60034-2-1:2014. (By the summation of all separate losses, including additional load loss)

IE3

PERFORMANCE VALUES

Standard 3 phase, Squirrel Cage Induction Motors
 IP 55 protection, IC 411 cooling, F class insulation, B temperature rise
 IE3: Premium Efficiency Class (IEC 60034-30-1:2014)

8 Pole, 750 rpm; 400 V 50 Hz

ALUMINIUM FRAME

STANDARD MOTORS

Output Power kW	Motor Type	Product Code	Speed n rpm	Current I_N A	Torque T_N Nm	Power Factor $\cos\phi$	Efficiency			Starting Current Ratio I_s / I_N	Starting Torque Ratio T_s / T_N	Breakdown Torque Ratio T_K / T_N	Moment of Inertia J kgm ²	Weight B3 kg
							4/4 Load 100%	3/4 Load 75%	2/4 Load 50%					
2,2	3MAS 132SA8	3M0SA3E- 13SA8	720	7,75	29,2	0,50	81,9	81,0	78,0	4,3	2,0	3,6	0,0460	27
3	3MAS 132MA8	3M0SA3E- 13MA8	720	9,97	39,8	0,52	83,5	83,0	81,2	4,6	2,1	3,7	0,0556	35
4	3MAS 160MA8	3M0SA3E- 16MA8	730	12,8	52,3	0,53	84,8	85,0	84,2	4,7	2,1	3,5	0,0793	69
5,5	3MAS 160MB8	3M0SA3E- 16MB8	730	17,1	71,9	0,54	86,2	86,3	85,6	4,8	2,2	3,5	0,0956	78
7,5	3MAS 160LA8	3M0SA3E- 16LA8	735	22,1	97,4	0,56	87,3	87,0	85,6	5,0	2,4	3,3	0,128	99
11	3MAS 180LA8	3M0SA3E- 18LA8	730	28,8	144	0,62	88,6	88,4	86,2	5,5	2,4	3,6	0,196	145
15	3MAS 200LA8	3M0SA3E- 20LA8	732	35,5	196	0,68	89,6	90,2	89,8	5,6	2,1	3,1	0,460	181
18,5	3MAS 225SA8	3M0SA3E- 22SA8	736	40,0	240	0,74	90,1	90,5	90,2	5,8	2,2	2,7	0,705	218
22	3MAS 225MA8	3M0SA3E- 22MA8	735	45,5	289	0,77	90,6	90,8	90,1	6,0	2,3	2,8	0,837	245
30	3MAS 250MA8	3M0SA3E- 25MA8	735	66,8	390	0,79	91,3	91,5	91,2	6,4	2,5	3,0	1,40	345

Efficiency values are determined according to IEC 60034-2-1:2014. (By the summation of all separate losses, including additional load loss)

IE3

PERFORMANCE VALUES

Standard 3 phase, Squirrel Cage Induction Motors
 IP 55 protection, IC 411 cooling, F class insulation, B temperature rise
 IE3: Premium Efficiency Class (IEC 60034-30-1:2014)

8 Pole, 750 rpm; 400 V 50 Hz

CAST IRON FRAME

STANDARD MOTORS

Output Power kW	Motor Type	Product Code	Speed n rpm	Current I _N A	Torque T _N Nm	Power Factor cosφ	Efficiency			Starting Current Ratio I _Δ /I _N	Starting Torque Ratio T _A /T _N	Breakdown Torque Ratio T _K /T _N	Moment of Inertia J kgm ²	Weight B3 kg
							4/4 Load 100%	3/4 Load 75%	2/4 Load 50%					
4	3MGS 160MA8	3M0SG3E- 16MA8	730	12,8	52,3	0,53	84,8	85,0	84,2	4,7	2,1	3,5	0,0793	97
5,5	3MGS 160MB8	3M0SG3E- 16MB8	730	17,1	71,9	0,54	86,2	86,3	85,6	4,8	2,2	3,5	0,0956	106
7,5	3MGS 160LA8	3M0SG3E- 16LA8	735	22,1	97,4	0,56	87,3	87,0	85,6	5,0	2,4	3,3	0,128	127
11	3MGS 180LA8	3M0SG3E- 18LA8	730	28,8	144	0,62	88,6	88,4	86,2	5,5	2,4	3,6	0,196	183
15	3MGS 200LA8	3M0SG3E- 20LA8	732	35,5	196	0,68	89,6	90,2	89,8	5,6	2,1	3,1	0,460	220
18,5	3MGS 225SA8	3M0SG3E- 22SA8	736	40,0	240	0,74	90,1	90,5	90,2	5,8	2,2	2,7	0,705	263
22	3MGS 225MA8	3M0SG3E- 22MA8	735	45,5	286	0,77	90,6	90,8	90,1	6,0	2,3	2,8	0,837	290
30	3MGS 250MA8	3M0SG3E- 25MA8	735	66,8	390	0,71	91,3	91,5	91,2	6,4	2,5	3,0	1,40	396
37	3MGS 280SA8	3M0SG3E- 28SA8	740	88,0	478	0,66	91,8	92,4	92,2	6,2	2,2	2,7	2,20	453
45	3MGS 280MA8	3M0SG3E- 28MA8	741	104	580	0,68	92,2	92,3	91,5	6,4	2,3	2,8	2,59	498
55	3MGS 315SA8	3M0SG3E- 31SA8	745	124	705	0,69	92,5	92,5	91,8	6,5	1,8	2,7	3,92	766
75	3MGS 315MA8	3M0SG3E- 31MA8	745	163	961	0,71	93,1	93,0	92,2	6,3	1,7	2,6	5,34	804
90	3MGS 315MB8	3M0SG3E- 31MB8	743	193	1157	0,72	93,4	93,5	92,5	6,8	1,9	2,7	6,32	879
110	3MGS 315MC8	3M0SG3E- 31MC8	742	232	1416	0,73	93,7	93,7	93,0	6,7	1,9	2,6	7,30	936
132	3MGS 355MA8	3M0SG3E- 35MA8	745	270	1692	0,75	94,0	94,0	93,3	7,2	1,4	2,5	8,51	1320
160	3MGS 355MB8	3M0SG3E- 35MB8	745	327	2051	0,75	94,3	94,2	93,5	7,4	1,5	2,6	10,2	1590
200	3MGS 355MC8	3M0SG3E- 35MC8	745	396	2564	0,77	94,6	94,6	94,0	7,2	1,4	2,5	11,6	1745
250	3MGS 355LA8	3M0SG3E- 35LA8	745	483	3205	0,79	94,6	94,3	93,8	7,2	1,5	2,6	13,5	1900
315	3MGS 355LB8	3M0SG3E- 35LB8	745	608	4037	0,79	94,6	94,3	95,4	6,5	1,5	2,2	14,4	2145
400	3MGS 355LC8	3M0SG3E- 35LC8	745	773	5127	0,79	94,6	94,6	94,1	6,5	1,4	2,1	15,3	2333
355	3MGS 400LA8	3M0SG3E- 40LA8	745	669	4550	0,81	94,6	94,8	94,5	7,1	1,3	2,5	19,1	2700
400	3MGS 400LB8	3M0SG3E- 40LB8	745	753	5127	0,81	94,6	94,8	95,4	7,2	1,3	2,1	22,0	2805
450	3MGS 400LC8	3M0SG3E- 40LC8	745	848	5768	0,81	94,6	94,7	94,7	7,5	1,2	2,0	24,5	2911

COMPACT MOTORS

Output Power kW	Motor Type	Product Code	Speed n rpm	Current I _N A	Torque T _N Nm	Power Factor cosφ	Efficiency			Starting Current Ratio I _Δ /I _N	Starting Torque Ratio T _A /T _N	Breakdown Torque Ratio T _K /T _N	Moment of Inertia J kgm ²	Weight B3 kg
							4/4 Load 100%	3/4 Load 75%	2/4 Load 50%					
132	3MGS 315MK8	3M0SG3E- 31MK8	744	253	1694	0,80	94,0	94,0	92,8	6,8	1,7	2,6	8,27	1056

Efficiency values are determined according to IEC 60034-2-1:2014. (By the summation of all separate losses, including additional load loss)



PERFORMANCE VALUES

Standard 3 phase, Squirrel Cage Induction Motors
 IP 55 protection, IC 411 cooling, F class insulation, B temperature rise
 IE4: Super Premium Efficiency Class (IEC 60034-30-1:2014)

2 Pole, 3000 rpm; 400 V 50 Hz

ALUMINIUM FRAME

STANDARD MOTORS

Output Power kW	Motor Type	Product Code	Speed n rpm	Current I_N A	Torque T_N Nm	Power Factor $\cos\phi$	Efficiency			Starting Current Ratio I_s / I_N	Starting Torque Ratio T_s / T_N	Breakdown Torque Ratio T_K / T_N	Moment of Inertia J kgm ²	Weight B3 kg
							4/4 Load 100%	3/4 Load 75%	2/4 Load 50%					
0,37	3MAS 71MA2	3M0SA4E-07MA2	2870	0,95	1,23	0,72	78,1	77,9	75,4	4,7	2,1	3,4	0,0005	6
0,55	3MAS 71MB2	3M0SA4E-07MB2	2870	1,30	1,83	0,75	81,5	81,6	79,8	6,6	3,3	4,9	0,0009	7
0,75	3MAS 80MA2	3M0SA4E-08MA2	2895	1,74	2,47	0,74	83,5	83,4	80,4	6,0	3,0	4,0	0,0011	10
1,1	3MAS 80MB2	3M0SA4E-08MB2	2895	2,30	3,63	0,80	85,2	85,3	83,1	7,3	3,3	4,0	0,0014	12
1,5	3MAS 90SA2	3M0SA4E-09SA2	2910	3,00	4,92	0,83	86,5	87,1	85,4	7,3	2,8	3,7	0,0023	15
2,2	3MAS 90LA2	3M0SA4E-09LA2	2910	4,36	7,22	0,82	88,0	88,7	87,8	7,7	3,0	3,8	0,0030	19
3	3MAS 100LA2	3M0SA4E-10LA2	2930	5,64	9,80	0,86	89,1	89,7	88,7	8,7	3,4	4,5	0,0049	25
4	3MAS 112MA2	3M0SA4E-11MA2	2910	7,18	13,1	0,89	90,0	90,9	90,6	7,9	2,8	3,5	0,0080	30
5,5	3MAS 132SA2	3M0SA4E-13SA2	2930	10,3	17,9	0,85	90,9	91,5	90,8	7,1	2,9	3,3	0,0168	44
7,5	3MAS 132SB2	3M0SA4E-13SB2	2930	13,7	24,4	0,86	91,7	92,4	92,1	7,3	2,9	3,3	0,0210	51
11	3MAS 160MA2	3M0SA4E-16MA2	2955	19,4	35,5	0,88	92,6	92,8	91,9	8,3	3,0	3,4	0,0502	90
15	3MAS 160MB2	3M0SA4E-16MB2	2955	26,1	48,5	0,88	93,3	93,6	93,1	8,0	2,6	3,2	0,0646	108
18,5	3MAS 160LA2	3M0SA4E-16LA2	2955	31,5	59,8	0,90	93,7	94,3	94,1	7,9	2,8	3,1	0,0764	135
22	3MAS 180MA2	3M0SA4E-18MA2	2965	36,7	70,9	0,92	94,0	94,6	94,5	8,4	2,9	3,3	0,131	192
30	3MAS 200LA2	3M0SA4E-20LA2	2970	51,0	96,5	0,89	94,5	94,6	94,1	9,4	3,5	3,5	0,219	199
37	3MAS 200LB2	3M0SA4E-20LB2	2970	62,6	119	0,90	94,8	95,0	94,5	9,1	3,4	3,4	0,241	258
45	3MAS 225MA2	3M0SA4E-22MA2	2975	74,8	144	0,91	95,0	95,2	94,6	8,6	2,6	3,1	0,392	293
55	3MAS 250MA2	3M0SA4E-25MA2	2980	92,0	176	0,90	95,3	95,3	94,6	7,5	2,4	3,0	0,524	400

COMPACT MOTORS

Output Power kW	Motor Type	Product Code	Speed n rpm	Current I_N A	Torque T_N Nm	Power Factor $\cos\phi$	Efficiency			Starting Current Ratio I_s / I_N	Starting Torque Ratio T_s / T_N	Breakdown Torque Ratio T_K / T_N	Moment of Inertia J kgm ²	Weight B3 kg
							4/4 Load 100%	3/4 Load 75%	2/4 Load 50%					
75	3MAS 250MK2	3M0SA4E-25MK2	2980	127	240	0,89	95,6	95,6	95,0	9,2	4,1	3,2	0,773	432

Efficiency values are determined according to IEC 60034-2-1:2014. (By the summation of all separate losses, including additional load loss)



PERFORMANCE VALUES

Standard 3 phase, Squirrel Cage Induction Motors
 IP 55 protection, IC 411 cooling, F class insulation, B temperature rise
 IE4: Super Premium Efficiency Class (IEC 60034-30-1:2014)

2 Pole, 3000 rpm; 400 V 50 Hz

CAST IRON FRAME

STANDARD MOTORS

Output Power kW	Motor Type	Product Code	Speed n rpm	Current I _N A	Torque T _N Nm	Power Factor cosφ	Efficiency			Starting Current Ratio I _s /I _N	Starting Torque Ratio T _s /T _N	Breakdown Torque Ratio T _K /T _N	Moment of Inertia J kgm ²	Weight B3 kg
							4/4 Load 100%	3/4 Load 75%	2/4 Load 50%					
11	3MGS 160MA2	3M0SG4E-16MA2	2955	19,4	35,5	0,88	92,6	92,8	91,9	8,3	3,0	3,4	0,0502	130
15	3MGS 160MB2	3M0SG4E-16MB2	2955	26,1	48,5	0,88	93,3	93,6	93,1	8,0	2,6	3,2	0,0646	141
18,5	3MGS 160LA2	3M0SG4E-16LA2	2955	31,5	59,8	0,90	93,7	94,3	94,1	7,9	2,8	3,1	0,0764	170
22	3MGS 180MA2	3M0SG4E-18MA2	2965	36,7	70,9	0,92	94,0	94,6	94,5	8,4	2,9	3,3	0,131	205
30	3MGS 200LA2	3M0SG4E-20LA2	2970	51,0	96,5	0,90	94,5	94,6	94,1	9,4	3,5	3,5	0,219	290
37	3MGS 200LB2	3M0SG4E-20LB2	2970	62,6	119	0,90	94,8	95,0	94,5	9,1	3,4	3,4	0,241	307
45	3MGS 225MA2	3M0SG4E-22MA2	2975	74,8	144	0,91	95,0	95,2	94,6	8,6	2,6	3,1	0,392	352
55	3MGS 250MA2	3M0SG4E-25MA2	2980	92,0	176	0,90	95,3	95,3	94,6	7,5	2,4	3,0	0,524	516
75	3MGS 280SA2	3M0SG4E-28SA2	2985	129	240	0,88	95,6	95,7	95,0	8,6	2,6	3,4	0,830	596
90	3MGS 280MA2	3M0SG4E-28MA2	2985	152	288	0,89	95,8	95,7	95,1	8,4	2,7	3,4	0,917	662
110	3MGS 315SA2	3M0SG4E-31SA2	2990	185	351	0,89	96,0	95,9	95,0	8,1	2,4	3,6	1,86	907
132	3MGS 315MA2	3M0SG4E-31MA2	2990	218	422	0,90	96,2	96,1	95,6	8,5	2,2	3,7	2,06	961
160	3MGS 315MB2	3M0SG4E-31MB2	2985	262	512	0,91	96,3	96,5	96,0	8	2,5	3,5	2,06	970
185	3MGS 315MC2	3M0SG4E-31MC2	2980	298	593	0,93	96,5	96,7	96,3	7,5	2,4	3,6	2,31	975
200	3MGS 315MD2	3M0SG4E-31MD2	2985	324	640	0,92	96,5	96,7	96,3	7,4	2,3	3,3	2,31	1041
250	3MGS 355MA2	3M0SG4E-35MA2	2985	418	800	0,89	96,5	96,4	95,9	8,4	2,2	3,8	3,81	1417
315	3MGS 355MB2	3M0SG4E-35MB2	2985	518	1008	0,90	96,5	96,6	96,2	8,6	2,3	3,8	4,63	1585
355	3MGS 355MC2	3M0SG4E-35MC2	2985	579	1136	0,91	96,5	96,7	96,3	9,6	2,8	3,9	5,72	1652
400	3MGS 355LA2	3M0SG4E-35LA2	2985	651	1280	0,91	96,5	96,6	96,3	9,2	2,4	3,9	5,74	1825
450	3MGS 355LB2	3M0SG4E-35LB2	2985	720	1440	0,93	96,5	96,7	96,5	8,9	2,4	4,2	7,21	2108
500	3MGS 355LC2	3M0SG4E-35LC2	2985	806	1600	0,92	96,5	96,6	96,3	9,8	2,7	4,9	7,97	2263
560	3MGS 400LA2	3M0SG4E-40LA2	2985	976	1791	0,91	96,5	96,6	96,1	8,4	2,6	3,8	9,22	3078
630	3MGS 400LB2	3M0SG4E-40LB2	2985	1036	2015	0,91	96,5	96,4	96,0	8,3	2,7	3,8	10,7	3295
710	3MGS 400LC2	3M0SG4E-40LC2	2985	1154	2271	0,92	96,5	96,4	95,8	8,2	2,7	3,6	11,9	3404

COMPACT MOTORS

Output Power kW	Motor Type	Product Code	Speed n rpm	Current I _N A	Torque T _N Nm	Power Factor cosφ	Efficiency			Starting Current Ratio I _s /I _N	Starting Torque Ratio T _s /T _N	Breakdown Torque Ratio T _K /T _N	Moment of Inertia J kgm ²	Weight B3 kg
							4/4 Load 100%	3/4 Load 75%	2/4 Load 50%					
75	3MGS 250MK2	3M0SA4E-25MK2	2980	127	240	0,89	95,6	95,6	95,0	9,2	4,1	3,2	0,773	510
110	3MGS 280MK2	3M0SG4E-28MK2	2985	187	352	0,90	96,0	96,2	95,8	9,2	2,9	3,5	1,11	704

Efficiency values are determined according to IEC 60034-2-1:2014. (By the summation of all separate losses, including additional load loss)



PERFORMANCE VALUES

Standard 3 phase, Squirrel Cage Induction Motors
 IP 55 protection, IC 411 cooling, F class insulation, B temperature rise
 IE4: Super Premium Efficiency Class (IEC 60034-30-1:2014)

4 Pole, 1500 rpm; 400 V 50 Hz

ALUMINIUM FRAME

STANDARD MOTORS

Output Power kW	Motor Type	Product Code	Speed n rpm	Current I_N A	Torque T_N Nm	Power Factor $\cos\phi$	Efficiency			Starting Current Ratio I_s / I_N	Starting Torque Ratio T_s / T_N	Breakdown Torque Ratio T_K / T_N	Moment of Inertia J kgm ²	Weight B3 kg
							4/4 Load 100%	3/4 Load 75%	2/4 Load 50%					
0,25	3MAS 71MA4	3M0SA4E-07MA4	1430	0,68	1,67	0,71	74,1	74,0	71,8	4,3	2,5	2,7	0,0011	7
0,37	3MAS 71MB4	3M0SA4E-07MB4	1430	0,98	2,47	0,70	78,0	77,8	75,7	5,0	3,4	3,5	0,0015	9
0,55	3MAS 80MA4	3M0SA4E-08MA4	1435	1,40	3,66	0,67	83,9	83,8	81,2	5,4	2,9	3,2	0,0021	12
0,75	3MAS 80MB4	3M0SA4E-08MB4	1440	1,93	4,97	0,65	85,7	85,5	82,6	6,0	3,5	3,8	0,0031	17
1,1	3MAS 90SA4	3M0SA4E-09SA4	1450	2,47	7,24	0,73	87,2	87,5	85,8	7,0	3,3	4,0	0,0045	18
1,5	3MAS 90LA4	3M0SA4E-09LA4	1450	3,33	9,90	0,73	88,2	88,5	87,1	7,5	3,5	4,2	0,0061	23
2,2	3MAS 100LA4	3M0SA4E-10LA4	1455	4,72	14,4	0,75	89,5	89,7	88,2	7,5	3,1	4,0	0,0089	26
3	3MAS 100LB4	3M0SA4E-10LB4	1460	6,48	19,6	0,73	90,4	90,6	89,4	8,4	3,7	4,5	0,0127	34
4	3MAS 112MA4	3M0SA4E-11MA4	1455	8,13	26,3	0,78	91,1	91,6	91,0	7,5	2,9	3,7	0,0167	37
5,5	3MAS 132SA4	3M0SA4E-13SA4	1470	11,0	35,7	0,78	91,9	92,4	91,7	7,2	2,8	3,3	0,0398	56
7,5	3MAS 132MA4	3M0SA4E-13MA4	1470	15,2	48,7	0,76	92,6	92,9	92,2	7,5	3,0	3,5	0,0481	67
11	3MAS 160MA4	3M0SA4E-16MA4	1480	21,5	71,0	0,79	93,3	93,4	92,6	7,7	3,2	3,3	0,102	103
15	3MAS 160LA4	3M0SA4E-16LA4	1475	28,6	97,1	0,80	93,9	94,3	93,8	6,7	2,5	2,9	0,133	125
18,5	3MAS 180MA4	3M0SA4E-18MA4	1480	35,0	119	0,80	94,2	94,7	94,3	6,6	2,7	2,5	0,197	152
22	3MAS 180LA4	3M0SA4E-18LA4	1480	42,4	142	0,79	94,5	94,8	94,3	7,2	3,1	2,8	0,227	171
30	3MAS 200LA4	3M0SA4E-20LA4	1480	53,0	194	0,86	94,9	95,3	95,0	7,5	2,4	3,1	0,364	229
37	3MAS 225SA4	3M0SA4E-22SA4	1485	65,5	238	0,85	95,2	95,4	95,1	8,9	3,3	3,4	0,636	302
45	3MAS 225MA4	3M0SA4E-22MA4	1485	79,2	289	0,86	95,4	95,7	95,5	8,4	3,1	3,2	0,762	342
55	3MAS 250MA4	3M0SA4E-25MA4	1490	97,7	352	0,84	95,7	95,6	94,9	9,2	3,4	3,3	1,17	456

Efficiency values are determined according to IEC 60034-2-1:2014. (By the summation of all separate losses, including additional load loss)



PERFORMANCE VALUES

Standard 3 phase, Squirrel Cage Induction Motors
 IP 55 protection, IC 411 cooling, F class insulation, B temperature rise
 IE4: Super Premium Efficiency Class (IEC 60034-30-1:2014)

4 Pole, 1500 rpm; 400 V 50 Hz

CAST IRON FRAME

STANDARD MOTORS

Output Power kW	Motor Type	Product Code	Speed n rpm	Current I _N A	Torque T _N Nm	Power Factor cosφ	Efficiency			Starting Current Ratio I _s /I _N	Starting Torque Ratio T _s /T _N	Breakdown Torque Ratio T _k /T _N	Moment of Inertia J kgm ²	Weight B3 kg
							4/4 Load 100%	3/4 Load 75%	2/4 Load 50%					
11	3MGS 160MA4	3M0SG4E- 16MA4	1480	21,5	71,0	0,79	93,3	93,4	92,6	7,7	3,2	3,3	0,102	134
15	3MGS 160LA4	3M0SG4E- 16LA4	1475	28,6	97,1	0,80	93,9	94,3	93,8	6,7	2,5	2,9	0,133	162
18,5	3MGS 180MA4	3M0SG4E- 18MA4	1480	35,0	119	0,80	94,2	94,7	94,3	6,6	2,7	2,5	0,197	193
22	3MGS 180LA4	3M0SG4E- 18LA4	1480	42,4	142	0,79	94,5	94,8	94,3	7,2	3,1	2,8	0,227	213
30	3MGS 200LA4	3M0SG4E- 20LA4	1480	53,0	194	0,86	94,9	95,3	95,0	7,5	2,4	3,1	0,364	263
37	3MGS 225SA4	3M0SG4E- 22SA4	1485	65,5	238	0,85	95,2	95,4	95,1	8,9	3,3	3,4	0,636	361
45	3MGS 225MA4	3M0SG4E- 22MA4	1485	79,2	289	0,86	95,4	95,7	95,5	8,4	3,1	3,2	0,762	402
55	3MGS 250MA4	3M0SG4E- 25MA4	1490	97,7	352	0,84	95,7	95,6	94,9	9,2	3,4	3,3	1,17	514
75	3MGS 280SA4	3M0SG4E- 28SA4	1490	134	481	0,84	96,0	95,9	95,2	8,5	3,2	3,2	2,02	702
90	3MGS 280MA4	3M0SG4E- 28MA4	1490	157	577	0,86	96,1	96,2	95,7	8,1	2,5	3,0	2,49	794
110	3MGS 315SA4	3M0SG4E- 31SA4	1490	193	705	0,85	96,3	96,4	96,0	8,0	2,4	3,2	3,61	949
132	3MGS 315MA4	3M0SG4E- 31MA4	1490	228	846	0,86	96,4	96,6	96,3	8,1	2,8	3,2	4,10	1003
160	3MGS 315MB4	3M0SG4E- 31MB4	1490	280	1025	0,85	96,6	96,7	96,3	9,3	3,1	3,8	4,73	1068
185	3MGS 315MC4	3M0SG4E- 31MC4	1490	313	1186	0,88	96,7	97,0	96,9	7,5	2,5	2,9	6,10	1243
200	3MGS 315MD4	3M0SG4E- 31MD4	1490	340	1282	0,87	96,7	96,8	96,5	8,3	2,6	3,5	6,10	1277
250	3MGS 355MA4	3M0SG4E- 35MA4	1490	432	1602	0,86	96,7	96,9	96,6	7,8	2,2	3,3	8,15	1603
315	3MGS 355MB4	3M0SG4E- 35MB4	1490	552	2019	0,85	96,7	96,8	96,5	8,3	2,5	3,5	0,73	1748
355	3MGS 355MC4	3M0SG4E- 35MC4	1490	612	2275	0,86	96,7	96,9	96,9	8,1	2,3	3,3	10,6	1792
400	3MGS 355LA4	3M0SG4E- 35LA4	1490	690	2564	0,86	96,7	97,0	96,8	7,6	2,2	3,2	10,6	1938
450	3MGS 355LB4	3M0SG4E- 35LB4	1490	790	2884	0,85	96,7	96,8	96,6	8,3	2,3	3,8	11,7	2064
500	3MGS 355LC4	3M0SG4E- 35LC4	1490	868	3204	0,86	96,7	96,8	96,6	8,3	2,3	3,4	13,0	2204
560	3MGS 355LD4	3M0SG4E- 35LD4	1490	959	3589	0,87	96,7	97,0	96,9	7,5	2,4	3,0	14,5	2392
560	3MGS 400LA4	3M0SG4E- 40LA4	1490	950	4038	0,88	96,7	96,7	96,3	8,0	2,3	3,0	15,3	3185
630	3MGS 400LB4	3M0SG4E- 40LB4	1490	1057	4038	0,89	96,7	96,8	96,4	8,2	2,2	3,1	16,5	3302
710	3MGS 400LC4	3M0SG4E- 40LC4	1490	1218	4550	0,87	96,7	96,7	96,4	8,2	2,3	3,2	17,4	3442

COMPACT MOTORS

Output Power kW	Motor Type	Product Code	Speed n rpm	Current I _N A	Torque T _N Nm	Power Factor cosφ	Efficiency			Starting Current Ratio I _s /I _N	Starting Torque Ratio T _s /T _N	Breakdown Torque Ratio T _k /T _N	Moment of Inertia J kgm ²	Weight B3 kg
							4/4 Load 100%	3/4 Load 75%	2/4 Load 50%					
110	3MGS 280MK4	3M0SG4E- 28MK4	1490	196	705	0,84	96,3	96,4	96,1	7,6	2,6	2,9	2,90	700

Efficiency values are determined according to IEC 60034-2-1:2014. (By the summation of all separate losses, including additional load loss)



PERFORMANCE VALUES

Standard 3 phase, Squirrel Cage Induction Motors
 IP 55 protection, IC 411 cooling, F class insulation, B temperature rise
 IE4: Super Premium Efficiency Class (IEC 60034-30-1:2014)

6 Pole, 1000 rpm; 400 V 50 Hz

ALUMINIUM FRAME

STANDARD MOTORS

Output Power kW	Motor Type	Product Code	Speed n rpm	Current I_N A	Torque T_N Nm	Power Factor $\cos\phi$	Efficiency			Starting Current Ratio I_s / I_N	Starting Torque Ratio T_s / T_N	Breakdown Torque Ratio T_K / T_N	Moment of Inertia J kgm ²	Weight B3 kg
							4/4 Load 100%	3/4 Load 75%	2/4 Load 50%					
0,18	3MAS 71MA6	3M0SA4E-07MA6	955	0,57	1,80	0,65	70,1	70,6	69,3	3,0	2,1	2,6	0,0009	7
0,25	3MAS 71MB6	3M0SA4E-07MB6	955	0,75	2,50	0,65	74,1	74,3	73,2	3,2	2,2	2,9	0,0013	8
0,37	3MAS 80MA6	3M0SA4E-08MA6	960	1,03	5,35	0,66	78,0	78,5	77,1	3,2	2,3	3,3	0,0022	10
0,55	3MAS 80MB6	3M0SA4E-08MB6	960	1,49	5,47	0,66	80,9	81,2	79,9	3,7	2,4	3,2	0,0038	13
0,75	3MAS 90SA6	3M0SA4E-09SA6	965	1,98	7,42	0,66	82,7	82,9	81,5	3,8	2,4	3,1	0,0057	15
1,1	3MAS 90LA6	3M0SA4E-09LA6	965	2,80	10,9	0,67	84,5	84,6	82,5	4,0	2,5	2,9	0,0089	20
1,5	3MAS 100LA6	3M0SA4E-10LA6	965	3,71	14,8	0,68	85,9	85,7	83,6	4,4	2,5	3,0	0,0162	27
2,2	3MAS 112MA6	3M0SA4E-11MA6	970	5,27	21,7	0,69	87,4	87,9	87,3	4,9	2,6	3,2	0,0223	35
3	3MAS 132SA6	3M0SA4E-13SA6	970	7,05	29,5	0,69	88,6	88,8	87,2	5,9	2,6	3,0	0,0366	43
4	3MAS 132MA6	3M0SA4E-13MA6	975	9,06	39,2	0,71	89,5	90,0	88,9	6,0	2,5	2,9	0,0473	53
5,5	3MAS 132MB6	3M0SA4E-13MB6	975	12,1	53,9	0,72	90,5	90,7	89,4	6,4	2,5	3,1	0,0610	70
7,5	3MAS 160MA6	3M0SA4E-16MA6	980	16,4	73,1	0,72	91,3	91,5	90,7	6,7	2,4	3,6	0,102	84
11	3MAS 160LA6	3M0SA4E-16LA6	980	23,2	107	0,74	92,3	92,4	91,3	7,1	2,3	3,6	0,171	124
15	3MAS 180LA6	3M0SA4E-18LA6	980	30,7	146	0,75	92,9	93,3	92,7	6,6	2,5	3,0	0,235	149
18,5	3MAS 200LA6	3M0SA4E-20LA6	985	36,7	179	0,77	93,4	93,7	92,9	6,5	2,8	2,9	0,406	194
22	3MAS 200LB6	3M0SA4E-20LB6	985	42,4	213	0,79	93,7	94,1	93,7	7,5	2,7	3,3	0,500	224
30	3MAS 225MA6	3M0SA4E-22MA6	985	59,3	291	0,77	94,2	94,6	94,2	6,9	2,6	3,1	0,728	274
37	3MAS 250MA6	3M0SA4E-25MA6	990	70,6	357	0,80	94,5	94,8	94,4	7,7	2,8	3,1	1,14	388

Efficiency values are determined according to IEC 60034-2-1:2014. (By the summation of all separate losses, including additional load loss)



PERFORMANCE VALUES

Standard 3 phase, Squirrel Cage Induction Motors
 IP 55 protection, IC 411 cooling, F class insulation, B temperature rise
 IE4: Super Premium Efficiency Class (IEC 60034-30-1:2014)

6 Pole, 1000 rpm; 400 V 50 Hz

CAST IRON FRAME

STANDARD MOTORS

Output Power	Motor Type	Product Code	Speed n rpm	Current I _N A	Torque T _N Nm	Power Factor cosφ	Efficiency			Starting Current Ratio I _s /I _N	Starting Torque Ratio T _s /T _N	Breakdown Torque Ratio T _K /T _N	Moment of Inertia J kgm ²	Weight B3 kg
							4/4 Load	3/4 Load	2/4 Load					
							100%	75%	50%					
7,5	3MGS 160MA6	3M0SG4E- 16MA6	980	16,4	73,1	0,72	91,3	91,5	90,7	6,7	2,4	3,6	0,102	114
11	3MGS 160LA6	3M0SG4E- 16LA6	980	23,2	107	0,74	92,3	92,4	91,3	7,1	2,3	3,6	0,171	155
15	3MGS 180LA6	3M0SG4E- 18LA6	980	30,7	146	0,75	92,9	93,3	92,7	6,6	2,5	3,0	0,235	193
18,5	3MGS 200LA6	3M0SG4E- 20LA6	985	36,7	179	0,77	93,4	93,7	92,9	6,5	2,8	2,9	0,406	238
22	3MGS 200LB6	3M0SG4E- 20LB6	985	42,4	213	0,79	93,7	94,1	93,7	7,5	2,7	3,3	0,500	264
30	3MGS 225MA6	3M0SG4E- 22MA6	985	59,3	291	0,77	94,2	94,6	94,2	6,9	2,6	3,1	0,728	333
37	3MGS 250MA6	3M0SG4E- 25MA6	990	70,6	357	0,80	94,5	94,8	94,4	7,7	2,8	3,1	1,14	440
45	3MGS 280SA6	3M0SG4E- 28SA6	990	88,3	434	0,77	94,8	95,1	94,9	6,4	2,4	2,8	1,82	576
55	3MGS 280MA6	3M0SG4E- 28MA6	990	106	531	0,78	95,1	95,4	95,1	6,5	2,3	2,7	2,17	627
75	3MGS 315SA6	3M0SG4E- 31SA6	990	135	723	0,84	95,4	95,7	95,4	6,5	2,1	2,8	3,47	831
90	3MGS 315MA6	3M0SG4E- 31MA6	990	161	868	0,84	95,6	96,0	95,9	6,8	2,5	3,1	4,26	912
110	3MGS 315MB6	3M0SG4E- 31MB6	990	194	1061	0,85	95,8	95,9	95,7	6,3	2,2	2,9	5,23	1017
132	3MGS 315MC6	3M0SG4E- 31MC6	990	234	1273	0,84	96,0	96,4	96,3	6,6	2,4	2,9	7,12	1214
160	3MGS 355MA6	3M0SG4E- 35MA6	995	289	1536	0,83	96,2	96,4	96,3	7,7	2,6	2,8	9,25	1528
200	3MGS 355MB6	3M0SG4E- 35MB6	990	352	1929	0,85	96,3	96,6	96,5	6,9	2,2	2,6	10,6	1655
250	3MGS 355MC6	3M0SG4E- 35MC6	990	435	2411	0,85	96,5	96,7	96,6	7,6	2,5	2,9	13,0	1877
315	3MGS 355LA6	3M0SG4E- 35LA6	990	541	3038	0,87	96,6	97,0	97,1	7,5	2,4	2,7	16,2	2194
400	3MGS 400LA6	3M0SG4E- 40LA6	990	695	3858	0,86	96,6	96,8	96,4	8,1	2,7	3,1	18	2869
450	3MGS 400LB6	3M0SG4E- 40LB6	990	773	4341	0,87	96,6	96,7	96,1	8,7	3,3	3,6	19,1	2996
500	3MGS 400LC6	3M0SG4E- 40LC6	990	849	4823	0,88	96,6	96,5	96,0	8,4	3,2	3,6	21,8	3111
560	3MGS 400LD6	3M0SG4E- 40LD6	990	940	5402	0,89	96,6	96,7	96,2	7,9	2,7	3,1	23,3	3208

COMPACT MOTORS

Output Power	Motor Type	Product Code	Speed n rpm	Current I _N A	Torque T _N Nm	Power Factor cosφ	Efficiency			Starting Current Ratio I _s /I _N	Starting Torque Ratio T _s /T _N	Breakdown Torque Ratio T _K /T _N	Moment of Inertia J kgm ²	Weight B3 kg
							4/4 Load	3/4 Load	2/4 Load					
							100%	75%	50%					
75	3MGS 280MK6	3M0SG4E- 28MK6	985	147	727	0,77	95,4	96,1	96,0	8,5	3,7	3,7	2,55	676
160	3MGS 315MK6	3M0SG4E- 31MK6	995	286	1536	0,84	96,2	96,6	96,8	6,6	2,3	2,4	8,7	1212

Efficiency values are determined according to IEC 60034-2-1:2014. (By the summation of all separate losses, including additional load loss)



PERFORMANCE VALUES

Standard 3 phase, Squirrel Cage Induction Motors
 IP 55 protection, IC 411 cooling, F class insulation, B temperature rise
 IE4: Super Premium Efficiency Class (IEC 60034-30-1:2014)

8 Pole, 750 rpm; 400 V 50 Hz

ALUMINIUM FRAME

STANDARD MOTORS

Output Power kW	Motor Type	Product Code	Speed n rpm	Current I_N A	Torque T_N Nm	Power Factor $\cos\phi$	Efficiency			Starting Current Ratio I_A / I_N	Starting Torque Ratio T_A / T_N	Breakdown Torque Ratio T_K / T_N	Moment of Inertia J kgm ²	Weight B3 kg
							4/4 Load 100%	3/4 Load 75%	2/4 Load 50%					
2,2	3MAS 132SA8	3M0SA4E- 13SA8	720	7,50	29,2	0,50	84,5	84,6	80,5	4,3	2,0	3,6	0,0460	32
3	3MAS 132MA8	3M0SA4E- 13MA8	720	9,69	39,8	0,52	85,9	83,4	83,6	4,6	2,1	3,7	0,0556	44
4	3MAS 160MA8	3M0SA4E- 16MA8	730	12,5	52,3	0,53	87,1	87,3	86,3	4,7	2,1	3,5	0,0793	75
5,5	3MAS 160MB8	3M0SA4E- 16MB8	730	16,6	71,9	0,54	88,3	88,6	96,8	4,8	2,2	3,5	0,0956	98
7,5	3MAS 160LA8	3M0SA4E- 16LA8	735	21,6	97,4	0,56	89,3	90,0	97,9	5,0	2,2	3,3	0,128	129
11	3MAS 180LA8	3M0SA4E- 18LA8	730	28,3	144	0,62	90,4	90,3	97,8	5,5	2,4	3,6	0,196	185
15	3MAS 200LA8	3M0SA4E- 20LA8	732	34,9	196	0,68	91,2	91,8	91,4	5,6	2,1	3,1	0,460	201
18,5	3MAS 225SA8	3M0SA4E- 22SA8	736	39,5	240	0,74	91,7	92,1	91,9	5,8	2,2	2,7	0,705	254
22	3MAS 225MA8	3M0SA4E- 22MA8	735	44,8	289	0,77	92,1	92,3	91,5	6,0	2,3	2,8	0,837	340
30	3MAS 250MA8	3M0SA4E- 25MA8	735	59,1	390	0,79	92,7	92,9	90,9	6,4	2,5	3,0	1,40	388

Efficiency values are determined according to IEC 60034-2-1:2014. (By the summation of all separate losses, including additional load loss)



PERFORMANCE VALUES

Standard 3 phase, Squirrel Cage Induction Motors
 IP 55 protection, IC 411 cooling, F class insulation, B temperature rise
 IE4: Super Premium Efficiency Class (IEC 60034-30-1:2014)

8 Pole, 750 rpm; 400 V 50 Hz

CAST IRON FRAME

STANDARD MOTORS

Output Power kW	Motor Type	Product Code	Speed n rpm	Current I _N A	Torque T _N Nm	Power Factor cosφ	Efficiency			Starting Current Ratio I _s /I _N	Starting Torque Ratio T _A /T _N	Breakdown Torque Ratio T _K /T _N	Moment of Inertia J kgm ²	Weight B3 kg
							4/4 Load 100%	3/4 Load 75%	2/4 Load 50%					
4	3MGS 160MA8	3M0SG4E- 16MA8	730	12,5	52,3	0,53	87,1	87,3	86,3	4,7	2,1	3,5	0,0793	105
5,5	3MGS 160MB8	3M0SG4E- 16MB8	730	16,6	71,9	0,54	88,3	88,6	96,8	4,8	2,2	3,5	0,0956	112
7,5	3MGS 160LA8	3M0SG4E- 16LA8	735	21,6	97,4	0,56	89,3	90,0	97,9	5,0	2,2	3,3	0,128	139
11	3MGS 180LA8	3M0SG4E- 18LA8	730	28,3	144	0,62	90,4	90,3	97,8	5,5	2,4	3,6	0,196	208
15	3MGS 200LA8	3M0SG4E- 20LA8	732	34,9	196	0,68	91,2	91,8	91,4	5,6	2,1	3,1	0,460	235
18,5	3MGS 225SA8	3M0SG4E- 22SA8	736	39,5	240	0,74	91,7	92,1	91,9	5,8	2,2	2,7	0,705	288
22	3MGS 225MA8	3M0SG4E- 22MA8	735	44,8	289	0,77	92,1	92,3	91,5	6,0	2,3	2,8	0,837	330
30	3MGS 250MA8	3M0SG4E- 25MA8	735	59,1	390	0,79	92,7	92,9	90,9	6,4	2,5	3,0	1,40	421
37	3MGS 280SA8	3M0SG4E- 28SA8	740	86,9	478	0,66	93,1	93,5	93,3	6,2	2,2	2,7	2,20	533
45	3MGS 280MA8	3M0SG4E- 28MA8	741	102	580	0,68	93,4	93,6	92,9	6,4	2,3	2,8	2,59	577
55	3MGS 315SA8	3M0SG4E- 31SA8	745	123	705	0,69	93,7	94,1	93,9	6,5	1,8	2,7	3,92	812
75	3MGS 315MA8	3M0SG4E- 31MA8	745	162	961	0,71	94,2	94,4	93,7	6,3	1,7	2,6	5,34	848
90	3MGS 315MB8	3M0SG4E- 31MB8	743	191	1157	0,72	94,4	94,7	96,8	6,8	1,9	2,7	6,32	1050
110	3MGS 315MC8	3M0SG4E- 31MC8	742	230	1416	0,73	94,7	95,0	95,5	6,7	1,9	2,6	7,30	1136
132	3MGS 355MA8	3M0SG4E- 35MA8	745	268	1692	0,75	94,9	94,9	94,2	7,2	1,4	2,5	8,51	1473
160	3MGS 355MB8	3M0SG4E- 35MB8	745	324	2051	0,75	95,1	96,0	94,3	7,4	1,5	2,6	10,2	1807
200	3MGS 355MC8	3M0SG4E- 35MC8	745	393	2564	0,77	95,4	95,4	94,8	7,2	1,4	2,5	11,6	2129
250	3MGS 355LA8	3M0SG4E- 35LA8	745	479	3205	0,79	95,4	95,1	94,6	7,2	1,5	2,6	13,5	2666
315	3MGS 355LB8	3M0SG4E- 35LB8	745	603	4037	0,79	95,4	95,9	96,4	6,5	1,5	2,2	14,4	2940
400	3MGS 355LC8	3M0SG4E- 35LC8	745	766	5127	0,79	95,4	95,4	94,8	6,5	1,4	2,1	15,3	3115
355	3MGS 400LA8	3M0SG4E- 40LA8	745	663	2988	0,81	95,4	96,5	96,6	7,4	1,4	2,6	20,9	3208
400	3MGS 400LB8	3M0SG4E- 40LB8	745	747	3130	0,81	95,4	96,4	96,1	7,7	1,5	2,3	22,7	3323
450	3MGS 400LC8	3M0SG4E- 40LC8	745	851	3282	0,80	95,4	96,5	96,2	7,8	1,2	2,1	24,3	3410

Efficiency values are determined according to IEC 60034-2-1:2014. (By the summation of all separate losses, including additional load loss)

Innovative Design Flawless Performance

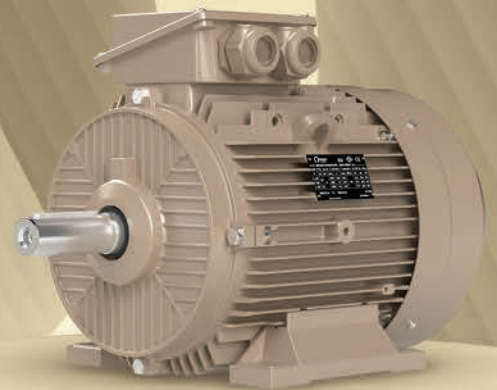
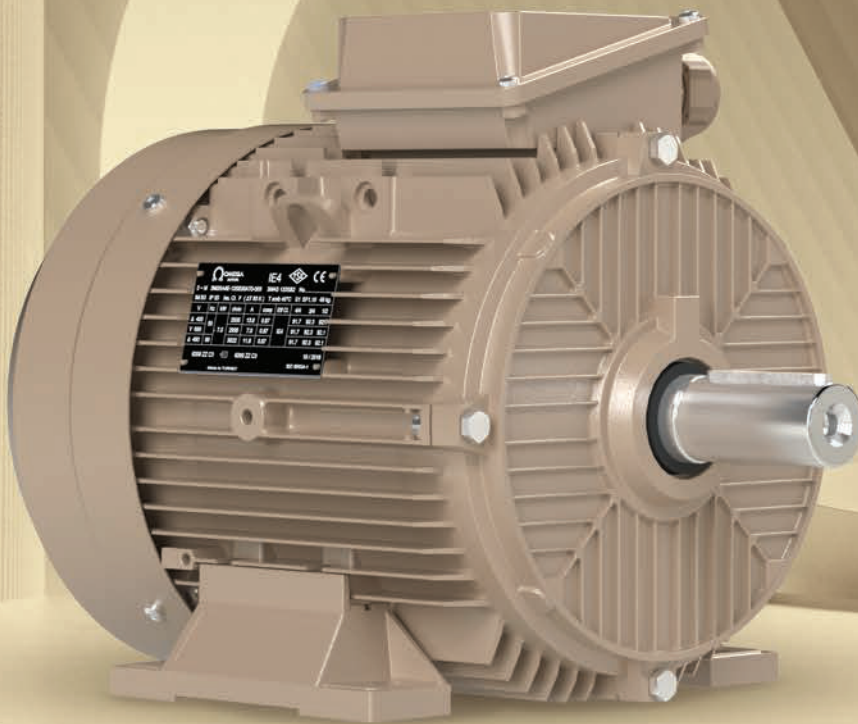

Experience
in Every Detail

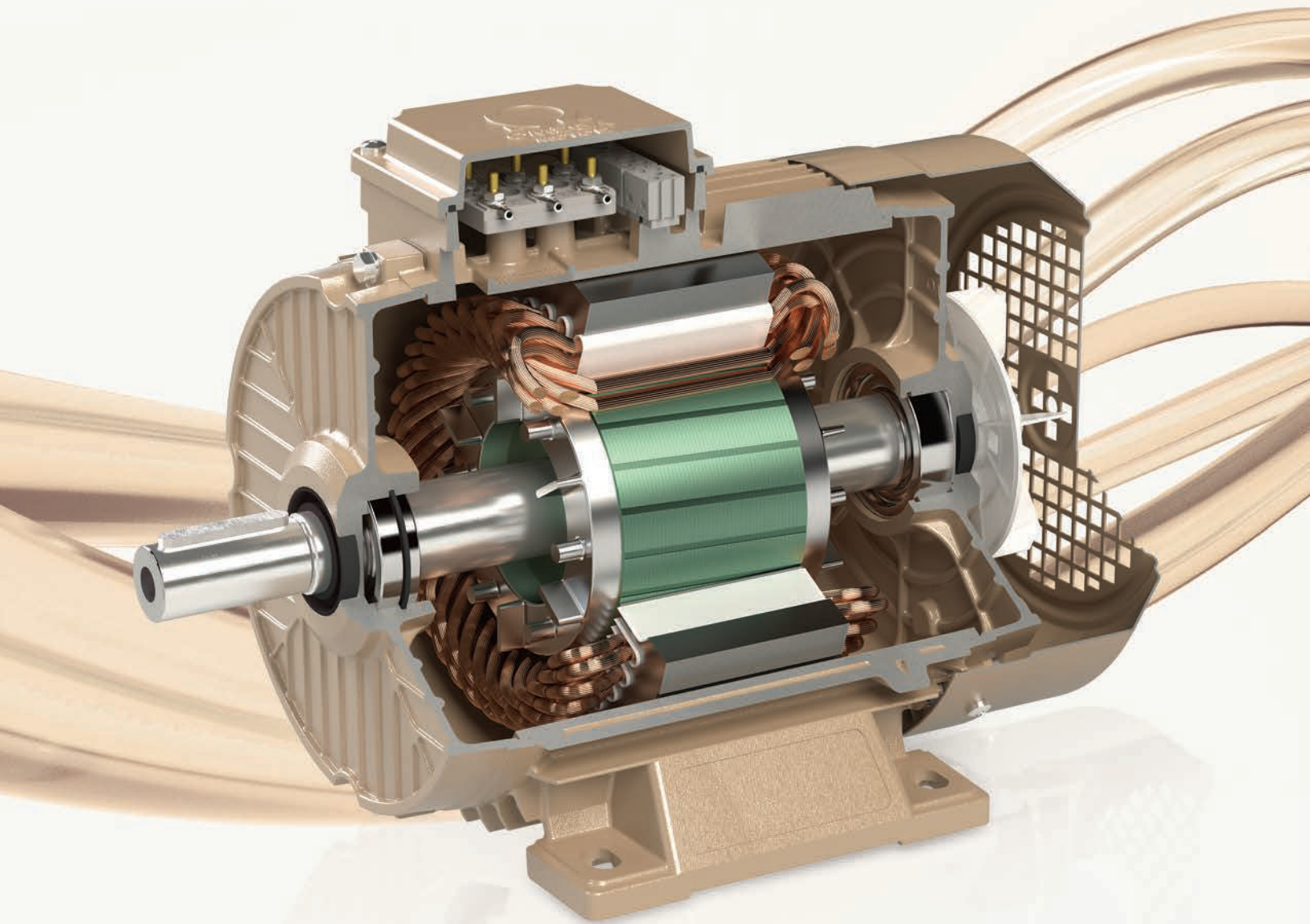

DEMAND CODES

Here is all additional features listed below for our standard induction motors. All requests should be specified with their codes in order. These features are applicable to both IE3 and IE4 motors. Note that there are some features that cannot be used together.

Code		Frame Size														
		71	80	90	100	112	132	160	180	200	225	250	280	315	355	400
Packaging																
A01	Overseas packing	o	o	o	o	o	o	o	o	o	o	o	o	o	o	o
A02	Overseas packing, wooden	o	o	o	o	o	o	o	o	o	o	o	o	o	o	o
A03	Packing of motor in vertical mounting position	o	o	o	o	o	o	o	o	o	o	o	o	o	o	o
Balancing																
B01	Vibration level grade B according to IEC 60034-14	o	o	o	o	o	o	o	o	o	o	o	o	o	o	o
B11	Full-key balancing	o	o	o	o	o	o	o	o	o	o	o	o	o	o	o
B12	Balanced without key	o	o	o	o	o	o	o	o	o	o	o	o	o	o	o
Painting																
B50	Unpainted motors (Just for aluminium frames)	o	o	o	o	o	o	o	o	o	o	o	x	x	x	x
B51	Primer paint only (Just for cast iron frames)	x	x	x	x	x	x	o	o	o	o	o	o	o	o	o
B52	Special paint colors, standard RAL codes	o	o	o	o	o	o	o	o	o	o	o	o	o	o	o
B53	Painting system C5	o	o	o	o	o	o	o	o	o	o	o	o	o	o	o
Name Plate																
E01	On right, stainless steel material (viewed from DE side)	o	o	o	o	o	o	o	o	o	o	o	o	o	o	o
E02	On left, stainless steel material (viewed from DE side)	o	o	o	o	o	o	o	o	o	o	o	o	o	o	o
E03	On left, aluminium material (viewed from DE side)	o	o	o	o	o	o	o	o	o	o	o	o	o	o	o
E04	2nd rating plate, aluminium material, affixed	o	o	o	o	o	o	o	o	o	o	o	o	o	o	o
E05	2nd rating plate, stainless steel material, affixed	o	o	o	o	o	o	o	o	o	o	o	o	o	o	o
E06	2nd rating plate, aluminium material, unmounted	o	o	o	o	o	o	o	o	o	o	o	o	o	o	o
E07	2nd rating plate, stainless steel material, unmounted	o	o	o	o	o	o	o	o	o	o	o	o	o	o	o
VZZ	Additional information on rating plate (max. 20 characters)	o	o	o	o	o	o	o	o	o	o	o	o	o	o	o
Cooling																
S01	IC 416 Cooling method, forced Cooling	o	o	o	o	o	o	o	o	o	o	o	o	o	o	o
S02	IC 410 Cooling method, without fan	o	o	o	o	o	o	o	o	o	o	o	o	o	o	o
S03	IC 418 Cooling method, cooling with driven fan by the motor itself	o	o	o	o	o	o	o	o	o	o	o	o	o	o	o
S04	IC 418 Cooling method, cooling with driven fan by the motor itself, closed shaft extension at NDE	o	o	o	o	o	o	o	o	o	o	o	o	o	o	o
S05	IC 410 Cooling method, without fan, closed shaft extension at NDE	o	o	o	o	o	o	o	o	o	o	o	o	o	o	o
Temperature Sensors																
T60	KTY 84 - 130, 1 set in stator winding	o	o	o	o	o	o	o	o	o	o	o	o	o	o	o
T02	Bimetal (Thermostat), 130°C, 1 set in stator winding	o	o	o	o	o	o	o	o	o	o	o	o	o	o	o
T01	Bimetal (Thermostat), 150°C, 1 set in stator winding	o	o	o	o	o	o	o	o	o	o	o	o	o	o	o
T03	Bimetal (Thermostat), 170°C, 1 set in stator winding	o	o	o	o	o	o	o	o	o	o	o	o	o	o	o
T20	PTC Thermistor, 130°C, 1 set in stator winding	o	o	o	o	o	o	o	o	o	o	o	o	o	o	o
T22	PTC Thermistor, 150°C, 1 set in stator winding	o	o	o	o	o	o	S	S	S	S	S	S	S	S	S
T21	PTC Thermistor, 170°C, 1 set in stator winding	o	o	o	o	o	o	o	o	o	o	o	o	o	o	o
T30	PTC Thermistor, 130°C - 3 and 150°C - 1 set in stator winding	o	o	o	o	o	o	o	o	o	o	o	o	o	o	o
T31	PTC Thermistor, 150°C - 3 and 170°C - 1 set in stator winding	o	o	o	o	o	o	o	o	o	o	o	o	o	o	o
T40	PT100, 2-wire, 1 set in stator winding	o	o	o	o	o	o	o	o	o	o	o	o	o	o	o
T50	PT100, 3-wire, 1 set in stator winding	o	o	o	o	o	o	o	o	o	o	o	o	o	o	o
R40	PT100, 2-wire, 1 set on bearings	x	x	x	x	x	o	o	o	o	o	o	o	o	o	o
R50	PT100, 3-wire, 1 set on bearings	x	x	x	x	x	o	o	o	o	o	o	o	o	o	o
Heating Elements																
H01	Heating elements, supply voltage 100V-120V	o	o	o	o	o	o	o	o	o	o	o	o	o	o	o
H02	Heating elements, supply voltage 200V-240V	o	o	o	o	o	o	o	o	o	o	o	o	o	o	o
Terminal Box																
K50	Brass cable glands	o	o	o	o	o	o	o	o	o	o	o	o	o	o	o
K51	Stainless steel cable glands	o	o	o	o	o	o	o	o	o	o	o	o	o	o	o

S : As standard

o : On request

x : Not applicable

Code		Frame Size														
		71	80	90	100	112	132	160	180	200	225	250	280	315	355	400
Shaft and Rotor																
M01	Shaft material stainless steel	o	o	o	o	o	o	o	o	o	o	o	o	o	o	o
M20	Shaft extension with open keyway	o	o	o	o	o	o	o	o	o	o	o	o	o	o	o
M21	Motor delivered with half key on its shaft	o	o	o	o	o	o	o	o	o	o	o	o	o	o	o
M22	Shaft extension without keyway	o	o	o	o	o	o	o	o	o	o	o	o	o	o	o
M29	Shaft extension on both sides according to customer specification	o	o	o	o	o	o	o	o	o	o	o	o	o	o	o
M30	Shaft extension on both sides, with dimensions as given in catalogue	o	o	o	o	o	o	o	o	o	o	o	o	o	o	o
M31	Special shaft extension dimensions at DE side, standard material	o	o	o	o	o	o	o	o	o	o	o	o	o	o	o
M32	Special shaft extension dimensions at NDE side, standard material	o	o	o	o	o	o	o	o	o	o	o	o	o	o	o
M33	Special shaft material according to customer specification	o	o	o	o	o	o	o	o	o	o	o	o	o	o	o
Motor Protection																
K01	Protection degree, IP 56	o	o	o	o	o	o	o	o	o	o	o	o	o	o	o
K02	Protection degree, IP 65	o	o	o	o	o	o	o	o	o	o	o	o	o	o	o
K03	Protection degree, IP 66	o	o	o	o	o	o	o	o	o	o	o	o	o	o	o
K10	V-ring	o	o	o	o	o	o	o	o	o	o	o	o	o	o	o
K20	Canopy	o	o	o	o	o	o	o	o	o	o	o	o	o	o	o
Bearing and Lubrication																
R01	Transport locking on bearings	x	x	x	x	x	x	o	o	o	o	o	o	o	o	o
R02	Vibration measurement nipples suitable for SPM	o	o	o	o	o	o	o	o	o	o	o	o	o	o	o
R10	Lubrication nipples and relubricable bearings	x	x	x	x	x	x	o	o	o	o	S	S	S	S	S
R17	Bearings greased for life (ZZ)	S	S	S	S	S	S	S	S	S	S	o	o	o	o	o
R11	Cylindrical roller bearing, DE side	x	x	x	x	x	x	o	o	o	o	o	o	o	o	o
R12	Angular contact ball bearing, shaft force towards bearing	x	x	x	x	x	x	o	o	o	o	o	o	o	o	o
R13	Angular contact ball bearing, shaft force away from bearing	x	x	x	x	x	x	o	o	o	o	o	o	o	o	o
R14	Same bearing both DE and NDE side (ZZ)	S	S	S	S	S	S	o	o	o	o	S	S	S	S	S
R15	Insulated bearing, NDE side	x	x	x	x	x	x	o	o	o	o	o	o	o	o	o
R16	Insulated endshield, NDE side	x	x	x	x	x	x	o	o	o	o	o	o	o	o	o
R19	Sealed bearings (2RS)	o	o	o	o	o	o	o	o	o	o	o	o	o	o	o
R20	DE Bearing located	o	o	o	o	o	o	o	o	o	o	S	S	S	S	S
R21	NDE Bearing located	o	o	o	o	o	o	S	S	S	S	o	o	o	o	o
Brake																
E50	Electromagnetic brake	o	o	o	o	o	o	o	o	o	o	o	o	o	o	o
Encoder																
F01	1024 Pulse encoder	o	o	o	o	o	o	o	o	o	o	o	o	o	o	o
Standardized Features																
X01	Motor designed for ambient temperature -40°C to 40°C	o	o	o	o	o	o	o	o	o	o	o	o	o	o	o
X07	Motor designed for ambient temperature -55°C to 40°C	o	o	o	o	o	o	o	o	o	o	o	o	o	o	o
X08	Motor designed for ambient temperature -20°C to 60°C	o	o	o	o	o	o	o	o	o	o	o	o	o	o	o
X02	Corrosion protected stator and rotor core	o	o	o	o	o	o	o	o	o	o	o	o	o	o	o
X03	Stainless steel or acid proof bolts	o	o	o	o	o	o	o	o	o	o	o	o	o	o	o
X04	Additional eyebolt on the top of frame, cast iron frames	x	x	x	x	x	x	o	o	o	o	S	S	S	S	S
X05	Additional eyebolt on the bottom of frame, cast iron frames	x	x	x	x	x	x	o	o	o	o	o	o	o	o	o
X06	Additional eyebolt on the top of frame, aluminium frames	x	x	x	x	x	x	o	o	o	o	o	x	x	x	x
P02	Special winding for non-standard voltage and frequency	o	o	o	o	o	o	o	o	o	o	o	o	o	o	o
Test																
T80	Type test report for one motor from specific delivery batch	o	o	o	o	o	o	o	o	o	o	o	o	o	o	o
T81	Test report for one motor from specific delivery batch	o	o	o	o	o	o	o	o	o	o	o	o	o	o	o
T82	Overvoltage test	o	o	o	o	o	o	o	o	o	o	o	o	o	o	o
T83	Vibration level test	o	o	o	o	o	o	o	o	o	o	o	o	o	o	o
T84	Noise level test for one motor from specific delivery batch	o	o	o	o	o	o	o	o	o	o	o	o	o	o	o
Earthing Bolts																
C01	Additional earthing bolt on motor frame, for aluminium motors	o	o	o	o	o	o	o	o	o	o	o	x	x	x	x
C02	Additional earthing bolt on motor frame, for cast iron motors	x	x	x	x	x	x	o	o	o	o	o	o	o	o	o
Insulation System																
Y01	H Class winding insulation	o	o	o	o	o	o	o	o	o	o	o	o	o	o	o
Y02	Special winding insulation for frequency converter supply	o	o	o	o	o	o	o	o	o	o	o	o	o	o	o

S : As standard

o : On request

x : Not applicable

DIMENSION DRAWINGS:

71 - 250M ALUMINIUM FRAME

IM B3 (IM 1001), IM B6 (IM 1051), IM B7 (IM 1061), IM B8 (IM 1071), IM V5 (IM 1011), IM V6 (IM 1031)

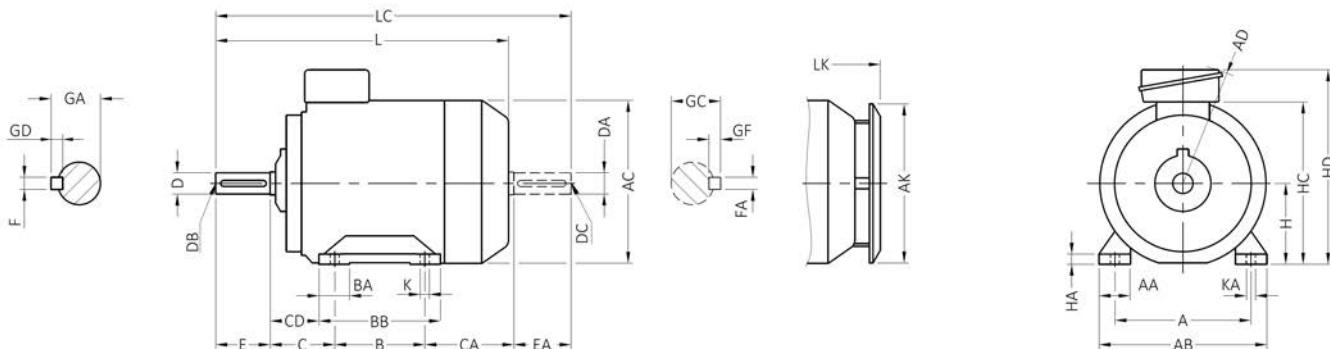

IM B35 (IM 2001), IM V15 (IM 2011)

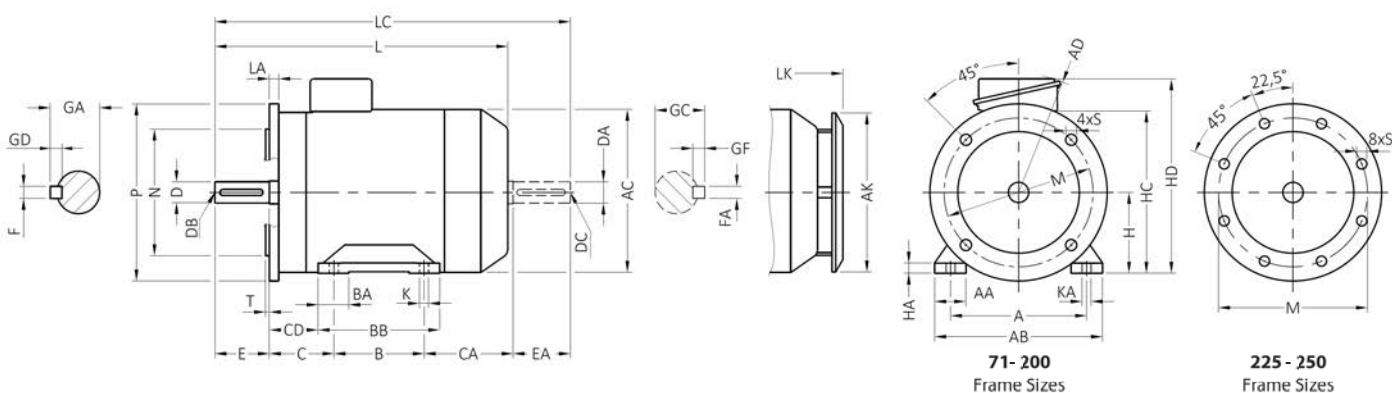

71- 200
Frame Sizes

225 - 250
Frame Sizes

TOLERANCES

D, DA	ISO j6	71M - 112M
	ISO k6	132S - 180L
	ISO m6	225M - 250M
N	ISO j6	71M - 180L
	ISO h6	200L - 250M
H	-0.5	250M
F, FA	ISO h6	

- Shoulder of shaft extension and contact surface of flange are in the same plane.
- The unit for all dimensions is mm.

- Please contact us for frame length information of 3M0SA4E-08MB4, 3M0SA3E-08MK4, 3M0SA4E-09SA4, 3M0SA4E-09LA4, 3M0SA3E-09LK4, 3M0SA4E-10LB4, 3M0SA3E-10LK4, 3M0SA4E-13SA2, 3M0SA4E-13SA4, 3M0SA4E-13MA4, 3M0SA3E-13MK4, 3M0SA4E-13MB6, 3M0SA3E-18MA2, 3M0SA4E-18MA2, 3M0SA3E-18MA4 and 3M0SA4E-18MA4.

Frame Size	Pole Number	A	AA	AB	AC	AD	B	BA	BB	C	CA	CD~	D DA	DB DC	E EA	F x GD FA x GF	GA GC	H	HA	HC	HD
71	2-4-6	112	35	150	146	112	90	27,5	109	45	82	35,5	14	M5	30	5x5	16	71	9	144	165
80	2-4-6	125	36	164	160	121	100	32	124	50	104	38	19	M6	40	6 x 6	21,5	80	12	174	195
90 S	2-4-6	140	40	184	180	130	100	32	124	56	112	44	24	M8	50	8 x 7	27	90	12	195	215
90 L	2-4-6	140	40	184	180	130	125	32	149	56	112	44	24	M8	50	8 x 7	27	90	12	195	215
100 L	2-4-6	160	45	208	204	141	140	42	174	63	117	46	28	M10	60	8 x 7	31	100	13	216	236
112 M	2-4-6	190	45	232	228	153	140	42	174	70	125	53	28	M10	60	8 x 7	31	112	13	240	260
132 S	2-4-6-8	216	50	274	270	195	140	46	174	89	128	71,5	38	M12	80	10 x 8	41	132	15	252	318
132 M	2-4-6-8	216	50	274	270	195	178	46	213	89	130	71,5	38	M12	80	10 x 8	41	132	15	252	318
160 M	2-4-6-8	254	62	332	328	252	210	60,5	255	108	190	85,5	42	M16	110	12 x 8	45	160	22	320	400
160 L	2-4-6-8	254	62	332	328	252	254	60,5	299	108	191	85,5	42	M16	110	12 x 8	45	160	22	320	400
180 M	2-4	279	64	364	358	264	241	65	286	121	237	98,5	48	M16	110	14 x 9	51,5	180	22	353	433
180 L	2-4-6-8	279	64	364	358	264	279	65	324	121	199	98,5	48	M16	110	14 x 9	51,5	180	22	353	433
200 L	2-4-6-8	318	69	408	408	300	305	67,5	355	133	243	108	55	M20	110	16 x 10	59	200	27	396	485
225 S	4-8	356	84	470	460	323	286	75	336	149	276	124	60	M20	140	18 x 11	64	225	30	445	534
225 M	2	356	84	470	460	323	311	75	361	149	251	124	55	M20	110	16 x 10	59	225	30	445	534
225 M	4-6-8	356	84	470	460	323	311	75	361	149	251	124	60	M20	140	18 x 11	64	225	30	445	534
250 M	2	406	100	516	513	377	349	100	416	168	259,5	132	60	M20	140	18 x 11	64	250	35	500	612
250 M	4-6-8	406	100	516	513	377	349	100	416	168	259,5	132	65	M20	140	18 x 11	69	250	35	500	612

DIMENSION DRAWINGS:

71M - 250M ALUMINIUM FRAME

IM B34 (IM 2101)

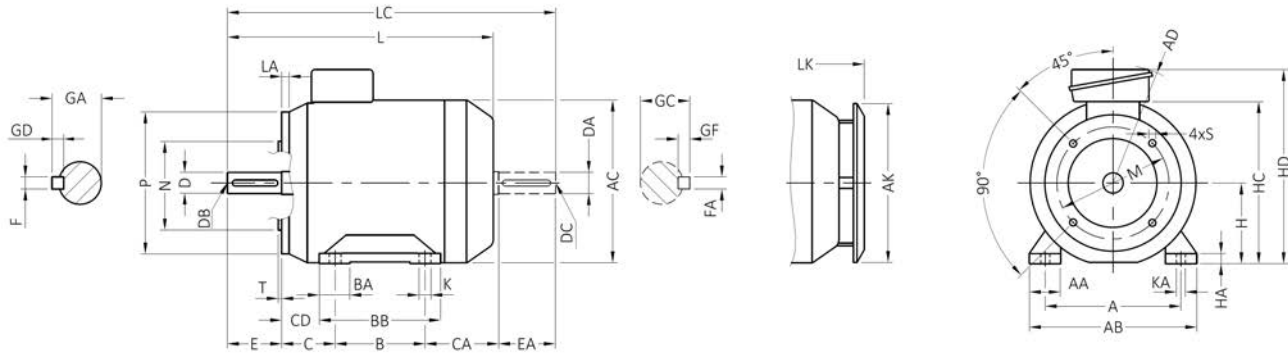

IM B5 (IM 3001), IM V1 (IM 3011), IM V3 (IM 3031)

*250M excluded.

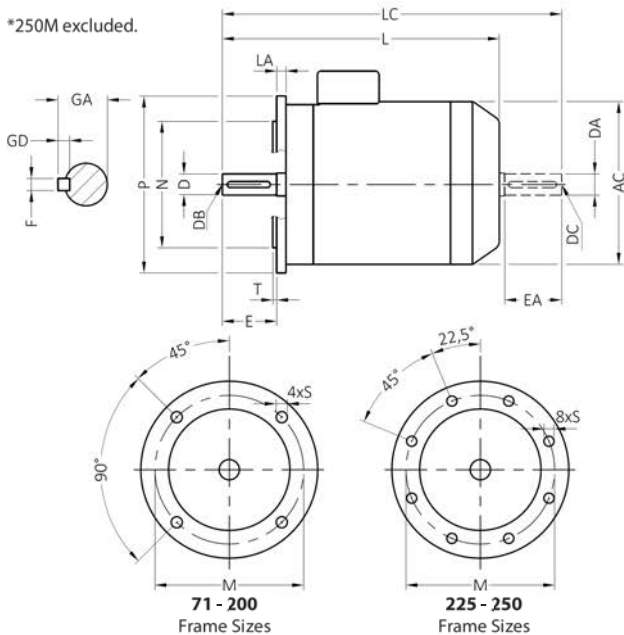

IM B14 (IM 3601), IM V18 (IM 3611), IM V19 (IM 3631)

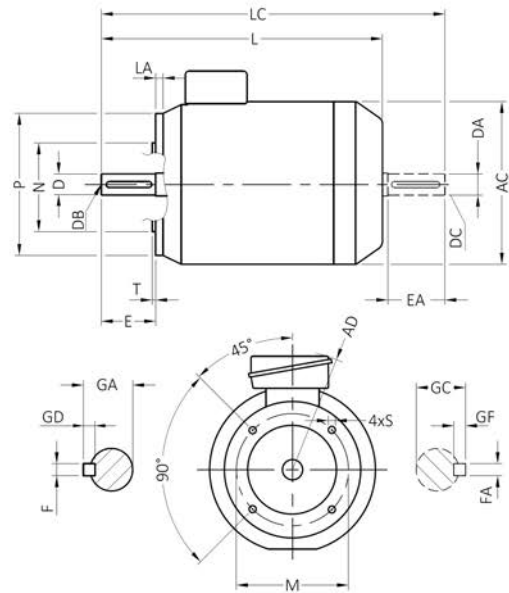

- Shoulder of shaft extension and contact surface of flange are in the same plane.
- The unit for all dimensions is mm.

Frame Size	Pole Number	Canopy		B5 Flange Dimensions										B14 Flange Dimensions						B14 - 2 Flange Dimensions						
		K	KA	L~	LC	AK	LK	Flange No.	LA	M	N	P	S	T	Flange No.	M	N	P	S	T	Flange No.	M	N	P	S	T
71	2-4-6	7	11	242	277	140	277	FF130	10	130	110	160	10x4	3,5	FT85	85	70	105	M6	2,5	FT115	115	95	140	M8	3
80	2-4-6	10	15	289	334	152	329	FF165	12	165	130	200	12	3,5	FT100	100	80	120	M6	3	FT130	130	110	160	M8	3,5
90 S	2-4-6	10	15	313	368	172	353	FF165	12	165	130	200	12	3,5	FT115	115	95	140	M8	3	FT130	130	110	160	M8	3,5
90 L	2-4-6	10	15	338	393	172	378	FF165	12	165	130	200	12	3,5	FT115	115	95	140	M8	3	FT130	130	110	160	M8	3,5
100 L	2-4-6	12	18	375	440	196	415	FF215	15	215	180	250	14,5	4	FT130	130	110	160	M8	3,5	FT165	165	130	200	M10	3,5
112 M	2-4-6	12	18	390	455	220	439,5	FF215	15	215	180	250	14,5	4	FT130	130	110	160	M8	3,5	FT165	165	130	200	M10	3,5
132 S	2-4-6-8	12	18	429	517	266	479	FF265	15	265	230	300	14,5	4	FT165	165	130	200	M10	3,5	FT215	215	180	250	M12	4
132 M	2-4-6-8	12	18	469	557	266	519	FF265	15	265	230	300	14,5	4	FT165	165	130	200	M10	3,5	FT215	215	180	250	M12	4
160 M	2-4-6-8	15	19	610	728	314	669,5	FF300	18	300	250	350	18,5	5	FT215	215	180	250	M12	4	-	-	-	-	-	-
160 L	2-4-6-8	15	19	655	773	314	714,5	FF300	18	300	250	350	18,5	5	FT215	215	180	250	M12	4	-	-	-	-	-	-
180 M	2-4	15	19	701	819	314	761	FF300	18	300	250	350	18,5	5	-	-	-	-	-	-	-	-	-	-	-	
180 L	2-4-6-8	15	19	701	819	314	761	FF300	18	300	250	350	18,5	5	-	-	-	-	-	-	-	-	-	-	-	
200 L	2-4-6-8	19	24	781	901	390	841	FF350	22	350	300	400	18,5	5	-	-	-	-	-	-	-	-	-	-	-	
225 S	4-8	19	24	841	961	390	900,5	FF400	22	400	350	450	18,5	5	-	-	-	-	-	-	-	-	-	-	-	
225 M	2	19	24	811	931	390	870,5	FF400	22	400	350	450	18,5	5	-	-	-	-	-	-	-	-	-	-	-	
225 M	4-6-8	28	24	906,5	1065,5	493	971,5	FF500	26	500	450	550	18,5	5	-	-	-	-	-	-	-	-	-	-	-	
250 M	2	28	24	906,5	1065,5	493	971,5	FF500	26	500	450	550	18,5	5	-	-	-	-	-	-	-	-	-	-	-	
250 M	4-6-8	28	24	906,5	1065,5	493	971,5	FF500	26	500	450	550	18,5	5	-	-	-	-	-	-	-	-	-	-	-	

DIMENSION DRAWINGS:

160M - 400L CAST IRON FRAME

IM B3 (IM 1001), IM B6 (IM 1051), IM B7 (IM 1061), IM B8 (IM 1071), IM V5 (IM 1011), IM V6 (IM 1031)

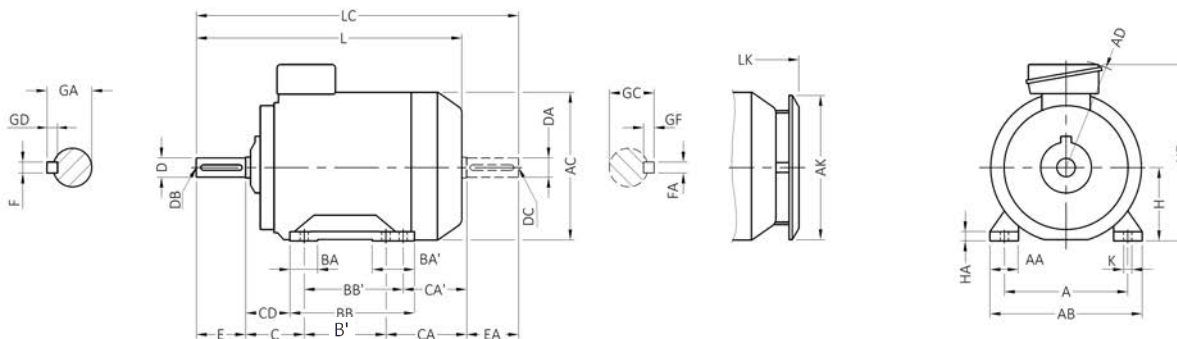

IM B35 (IM 2001), IM V15 (IM 2011)

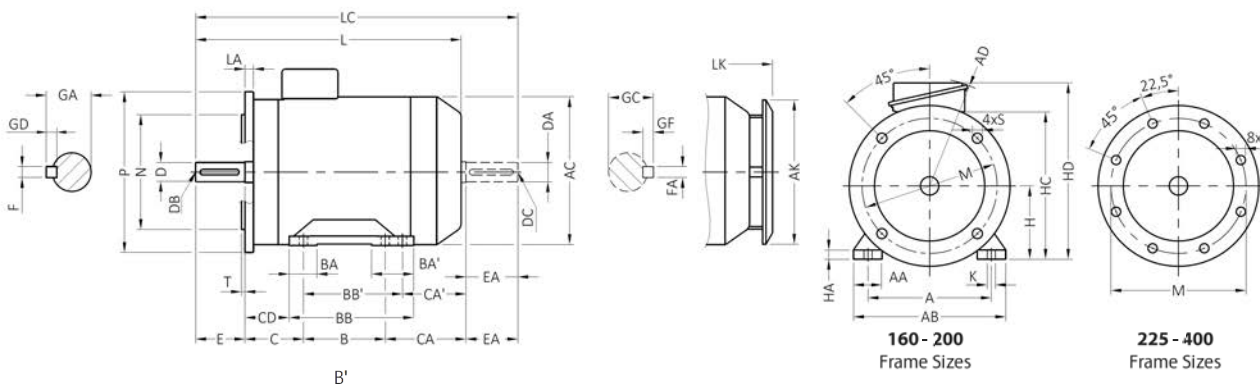

- Shoulder of shaft extension and contact surface of flange are in the same plane.
- The unit for all dimensions is mm.

- Please contact us for frame length information of 3M0SG3E-18MA4 and 3M0SG4E-18MA4.

TOLERANCES

D, DA	ISO k6	160M - 180L
	ISO m6	200L - 400L
N	ISO j6	160M - 180L
	ISO h6	200L - 400L
H	-0.5	160M - 250M
	-1	280M - 400L
F, FA	ISO h6	

Frame Size	Pole Number	A	AA	AB	AC	AD	B	B'	BA	BA'	BB	C	CA	CA'	CD~	D DA	DB DC	E EA	F x GD FA x GF	GA GC	H	HA	HD
160 M	2-4-6-8	254	62	332	328	252	210	-	60	-	255	108	189,5	-	85	42	M16	110	12 x 8	45	160	22	400
160 L	2-4-6-8	254	62	332	328	252	254	-	60	-	300	108	190,5	-	85	42	M16	110	12 x 8	45	160	22	400
180 M	2-4	279	64	364	358	264	241	-	65	-	287	121	202	-	98	48	M16	110	14 x 9	51,5	180	22	433
180 L	2-4-6-8	279	64	364	358	264	279	-	65	-	325	121	199	-	98	48	M16	110	14 x 9	51,5	180	22	433
200 L	2-4-6-8	318	80	410	408	300	305	-	71	-	354	133	243	-	108,5	55	M20	110	16 x 10	59	200	25	485
225 S	4-8	356	90	466	460	323	286	311	75	100	368	149	275,5	250,5	120,5	60	M20	140	18 x 11	64	225	30	534
225 M	2	356	90	466	460	323	286	311	75	100	368	149	275,5	250,5	120,5	55	M20	110	16 x 10	59	225	30	534
225 M	4-6-8	356	90	466	460	323	286	311	75	100	368	149	275,5	250,5	120,5	60	M20	140	18 x 11	64	225	30	534
250 M	2	406	100	516	513	377	349	-	100	-	421	168	259,5	-	132	60	M20	140	18 x 11	64	250	36	612,1
250 M	4-6-8	406	100	516	513	377	349	-	100	-	421	168	259,5	-	132	65	M20	140	18 x 11	69	250	36	612,1
280 S	2	457	110	606	600	413	368	-	100	-	440	190	323,5	-	154	65	M20	140	18 x 11	69	280	44	679,1
280 S	4-6-8	457	110	606	600	413	368	-	100	-	440	190	323,5	-	154	75	M20	140	20 x 12	79,5	280	44	679,1
280 M	2	457	110	606	600	413	419	-	100	-	491	190	272,5	-	154	65	M20	140	18 x 11	69	280	44	679,1
280 M	4-6-8	457	110	606	600	413	419	-	100	-	491	190	272,5	-	154	75	M20	140	20 x 12	79,5	280	44	679,1
315 S	2	508	135	680	675	557	406	457	120	170	540	216	373,5	322,5	174	65	M20	140	18 x 11	69	315	47	809
315 S	4-6-8	508	135	680	675	557	406	457	120	170	540	216	373,5	322,5	174	85	M20	170	22 x 14	90	315	47	809
315 M	2	508	135	680	675	557	406	457	120	170	540	216	373,5	322,5	174	65	M20	140	18 x 11	69	315	47	809
315 M	4-6-8	508	135	680	675	557	406	457	120	170	540	216	373,5	322,5	174	85	M20	170	22 x 14	90	315	47	809
315 L	2	508	135	680	675	557	508	630	120	242	714	216	421,5	299,5	174	65	M20	140	18 x 11	69	315	47	809
315 L	4-6	508	135	680	675	557	508	630	120	242	714	216	421,5	299,5	174	85	M20	170	22 x 14	90	315	47	809
355 M	2	610	157	770	760	588	560	-	143	-	665	254	399	-	201	80	M20	170	22 x 14	85	355	52	881
355 M	4-6-8	610	157	770	760	588	560	-	143	-	665	254	456	-	201	100	M24	210	28 x 16	106	355	52	881
355 L	2	610	164	770	760	588	630	800	141	304	900	254	529	359	201	80	M20	170	22 x 14	84	355	52	881
355 L	4-6-8	610	164	770	760	588	630	800	141	304	900	254	585	415	201	100	M24	210	28 x 16	106	355	52	881
400 L	2	686	164	870	875	675	800	900	155	265	995	224	445	346	174	80	M20	170	22x14	84	400	55	1055
400 L	4-6-8	686	164	870	875	675	800	900	155	265	995	224	445	346	174	110	M24	210	28x16	106	400	55	1055

DIMENSION DRAWINGS:

160M - 400L CAST IRON FRAME

IM B34 (IM 2101)

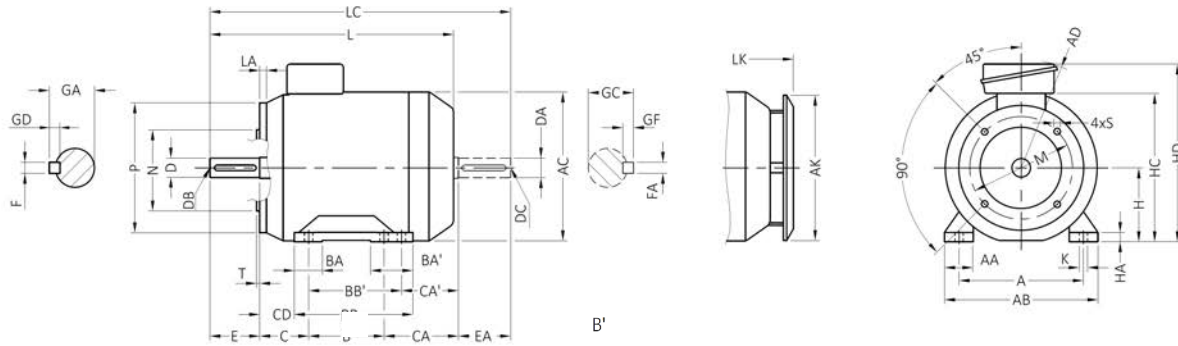

IM B5 (IM 3001), IM V1 (IM 3011), IM V3 (IM 3031)

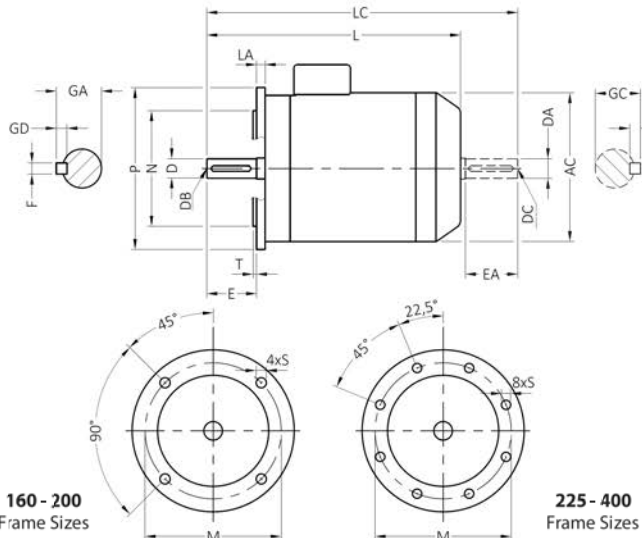

IM B14 (IM 3601), IM V18 (IM 3611), IM V19 (IM 3631)

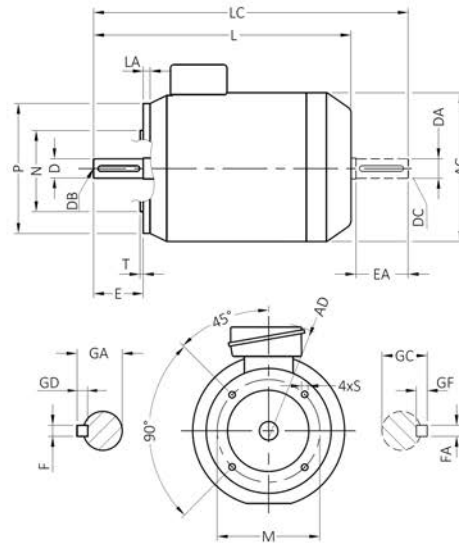

- Shoulder of shaft extension and contact surface of flange are in the same plane.
- The unit for all dimensions is mm.

Frame Size	Pole Number	K	L	LC	Canopy		B5 Flange Dimensions						B14 Flange Dimensions						
					AK	LK	Flange No.	LA	M	N	P	S	T	Flange No.	M	N	P	S	T
160 M	2-4-6-8	15	609,5	727,5	314	669,5	FF300	18	300	250	350	18,5	5	FT215	215	180	250	M12	4
160 L	2-4-6-8	15	654,5	772,5	314	714,5	FF300	18	300	250	350	18,5	5	FT215	215	180	250	M12	4
180 M	2-4-6-8	15	666	784	314	726	FF300	18	300	250	350	18,5	5	-	-	-	-	-	-
180 L	2-4-6-8	15	701	819	314	761	FF300	18	300	250	350	18,5	5	-	-	-	-	-	-
200 L	2-4-6-8	19	781	901	390	841	FF350	22	350	300	400	18,5	5	-	-	-	-	-	-
225 S	4-8	19	840,5	990,5	390	900,5	FF400	22	400	350	450	18,5	5	-	-	-	-	-	-
225 M	2	19	810,5	930,5	390	870,5	FF400	22	400	350	450	18,5	5	-	-	-	-	-	-
225 M	4-6-8	19	840,5	990,5	390	900,5	FF400	22	400	350	450	18,5	5	-	-	-	-	-	-
250 M	2	24	906,5	1056,5	493	971,5	FF500	26	500	450	550	18,5	5	-	-	-	-	-	-
250 M	4-6-8	24	906,5	1056,5	493	971,5	FF500	26	500	450	550	18,5	5	-	-	-	-	-	-
280 S	2	24	1011,5	1161,5	553	1076,5	FF500	26	500	450	550	18,5	5	-	-	-	-	-	-
280 S	4-6-8	24	1011,5	1161,5	553	1076,5	FF500	26	500	450	550	18,5	5	-	-	-	-	-	-
280 M	2	24	1011,5	1161,5	553	1076,5	FF500	26	500	450	550	18,5	5	-	-	-	-	-	-
280 M	4-6-8	24	1011,5	1161,5	553	1076,5	FF500	26	500	450	550	18,5	5	-	-	-	-	-	-
315 S	2	28	1125,5	1275,5	617	1190,5	FF600	26	600	550	660	24	6	-	-	-	-	-	-
315 S	4-6-8	28	1155,5	1335,5	617	1220,5	FF600	26	600	550	660	24	6	-	-	-	-	-	-
315 M	2	28	1125,5	1275,5	617	1190,5	FF600	26	600	550	660	24	6	-	-	-	-	-	-
315 M	4-6-8	28	1155,5	1335,5	617	1220,5	FF600	26	600	550	660	24	6	-	-	-	-	-	-
315 L	2	28	1275,5	1425,5	617	1340,5	FF600	26	600	550	660	24	6	-	-	-	-	-	-
315 L	4-6	28	1305,5	1485,5	617	1370,5	FF600	26	600	550	660	24	6	-	-	-	-	-	-
355 M	2	28	1368	1553	700	1440	FF740	34	740	680	800	24	6	-	-	-	-	-	-
355 M	4-6-8	28	1465	1690	700	1537	FF740	34	740	680	800	24	6	-	-	-	-	-	-
355 L	2	28	1568	1753	700	1670	FF740	34	740	680	800	24	6	-	-	-	-	-	-
355 L	4-6-8	28	1665	1830	700	1737	FF740	34	740	680	800	24	6	-	-	-	-	-	-
400 L	2	35	1640	1825	700	72	FF940	34	940	880	1000	28	6	-	-	-	-	-	-
400 L	4-6-8	35	1680	1905	700	72	FF940	34	940	880	1000	28	6	-	-	-	-	-	-

Designed for
Quality

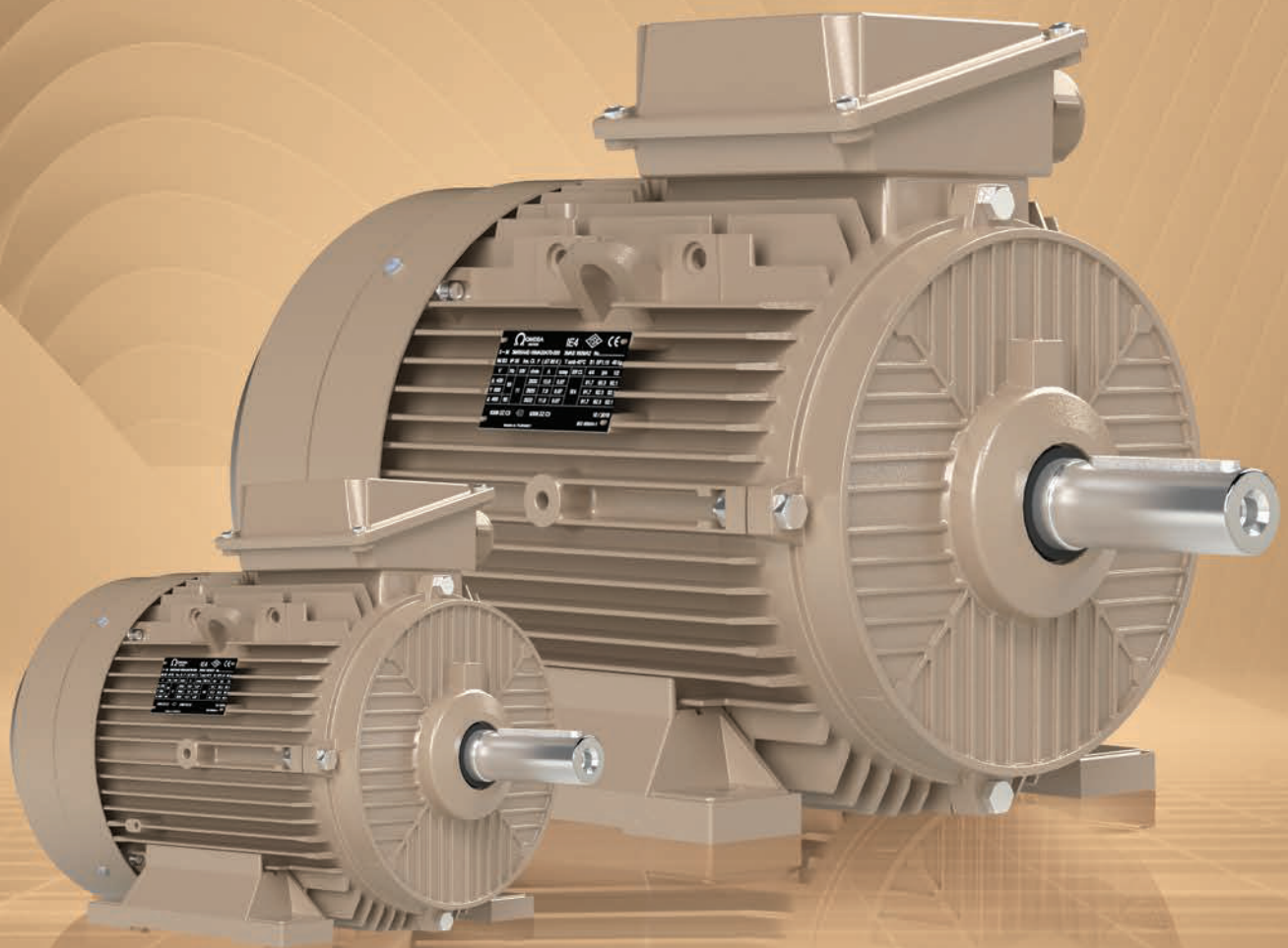

 **OMEGA**
MOTOR

Energy Transformation for **Efficiency**

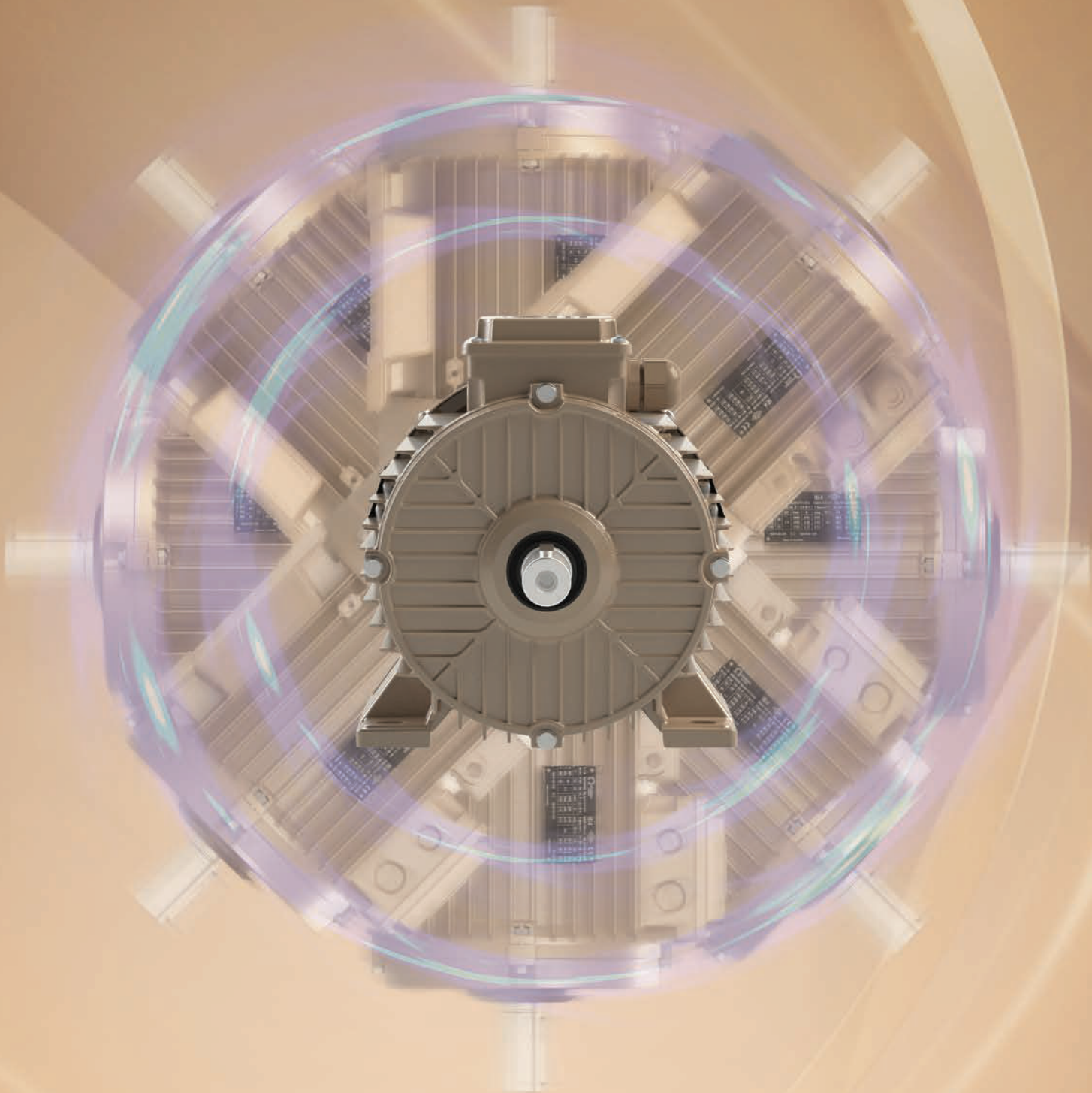

 **OMEGA**
MOTOR

MOTORS IN BRIEF: IE3 & IE4 MOTORS

71 - 112 ALUMINIUM FRAME

Frame Size	71	80	90	100	112
Frame	Pressure die-cast aluminium alloy				
End shields	Material	Pressure die-cast aluminium alloy			
Flange (B5)	Material	Pressure die-cast aluminium alloy			
Flange (B14)	Material	Pressure die-cast aluminium alloy			
Flange (B14-2)	Material	Pressure die-cast aluminium alloy			
Feet	Integrated/feet bolted to the frame, pressure die-cast aluminium feet				
Painting	Material	Acrylic -based paint, RAL 1019			
	Corrosion Class	C3; ISO 12944-2:2017			
Bearings	Locking	Floating bearing			
	Spring	NDE Side			
	DE Side	6202 ZZ/CM	6204 ZZ/CM	6205 ZZ/CM	6206 ZZ/CM
	NDE Side	6202 ZZ/CM	6204 ZZ/CM	6205 ZZ/CM	6206 ZZ/CM
	Seal	V-ring on both DE and NDE sides			
Lubrication	Grease	Permanently lubricated shielded bearings			
Vibration Measurement Nipples	On Request	SPM			
Terminal Box	Material	Pressure die-cast aluminium alloy			
	Position	Top as standard			
Cable Connections	Cable Glands	1 x M25		2 x M25	
	Terminal	6 terminals for connection with cable lugs (lugs not included)			
Stator Winding	Material	Enameled copper wire			
	Insulation	Insulation class F, temperature rise B			
	Winding Protection	On request			
Heating Elements	On Request	2 x 20W		2 x 30W	
Rotor Winding	Material	Medium pressure die-cast, pure aluminium			
Shaft	Material	AISI 1040			
	Screw Hole	M5	M6	M8	M10
Vibration	Grade A				
Balance	Half key method				
Shaft Key	Closed keyway				
Rating Plate	Material	Aluminium plate; 0,5 mm			
Earthing	One inside the terminal box and one on the frame next to the foot				
Protection Degree	IP 55 as standard, higher protection on request				
Cooling Method	Totally enclosed, fan cooled - IC 411				
Fan	Material	Polyethylene			
Fan Cover	Material	Steel			
Drain Holes	Material	PA 6			

71 - 112 ALUMINIUM FRAME

COMPONENTS:

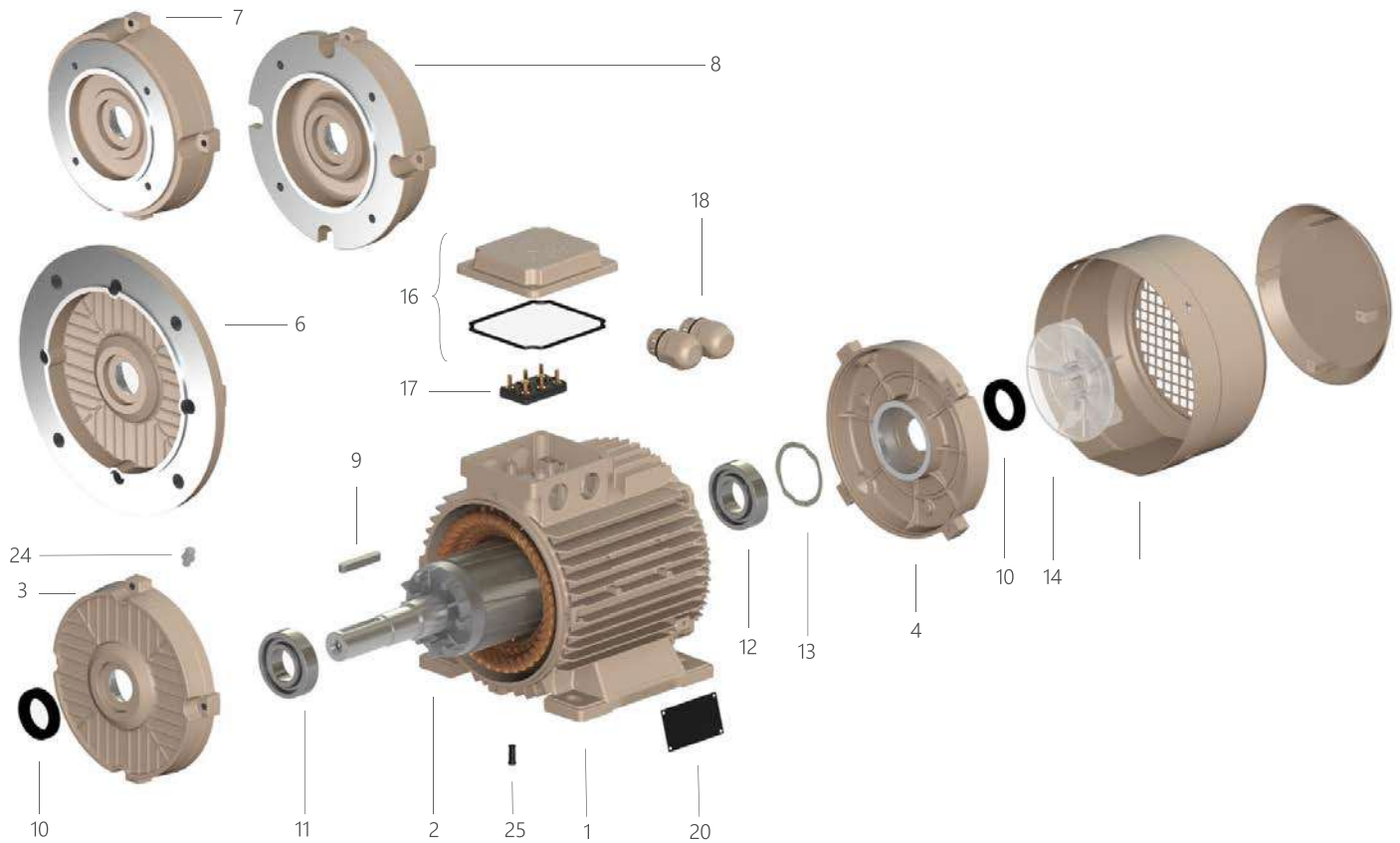

STANDARD DESIGN MOTORS

71 to 112 Frame Sizes

- 1 Frame and complete stator
- 2 Rotor with shaft
- 3 End shield, DE side
- 4 End shield, NDE side
- 6 B5 Flange
- 7 B14 Flange
- 8 B14 2nd Flange
- 9 Shaft key
- 10 V-Ring
- 11 Bearing, DE side
- 12 Bearing, NDE side
- 13 Wave spring
- 14 Fan
- 15 Fan cover
- 16 Terminal box cover
- 17 Terminal
- 18 Cable glands
- 20 Rating plate
- 23 Canopy
- 24 Vibration measurement nipple
- 25 Plug for drain hole

MOTORS IN BRIEF: IE3 & IE4 MOTORS

132 - 250 ALUMINIUM FRAME

Frame Size	132	160	180	200	225	250	
Frame	Pressure die-cast aluminium alloy						
End shields	Material	Pressure die-cast aluminium alloy			Cast iron GG 20		
Flange (B5)	Material	Pressure die-cast aluminium alloy	Cast iron GG 20				
Flange (B14)	Material	Pressure die-cast aluminium alloy	Cast iron GG 20	-			
Flange (B14-2)	Material	Pressure die-cast aluminium alloy	-				
Feet	Feet bolted to the frame, pressure die-cast aluminium					Integrated aluminium feet	
Painting	Material	Acrylic-based paint, RAL 1019	Epoxy based, RAL 1019				
	Corrosion Class	C3; ISO 12944-2:2017					
Bearings	Locking	Locked at NDE with a circlip				Locked at DE with end shield	
	Spring	DE Side				NDE Side	
	DE Side	6208 ZZ/C3	6309 ZZ/C3	6310 ZZ/C3	6312 ZZ/C3	6313 ZZ/C3	6315 C3
	NDE Side	6208 ZZ/C3	6209 ZZ/C3	6210 ZZ/C3	6212 ZZ/C3	6213 ZZ/C3	6315 C3
Seal	V-ring on both DE and NDE sides						
Lubrication	Grease	Permanently lubricated shielded bearings.				Mobil Polyrex EM	
	Relubrication	-	M8x1 greasing nipples on request			M8 x 1 greasing nipples as standard	
Vibration Measurement Nipples	On Request	SPM					
Terminal Box	Material	Pressure die-cast aluminium alloy					
	Position	Top as standard, changeable to LHS and RHS positions by simply bolting the feet accordingly				Top as standard	
Cable Connections	Cable Glands	2 x M32	2 x M40		2 x M50		2 x M63
	Terminal	6 terminals for connection with cable lugs (lugs not included)					
Stator Winding	Material	Enameled copper wire					
	Insulation	Insulation class F, Temperature rise B					
	Winding Protection	On request	150°C FTC Thermistors, 1 set as standard				
Heating Elements	On Request	2 x 30W			2 x 40W		
Rotor Winding	Material	Medium pressure die-cast, pure aluminium					
Shaft	Material	AISI 1040				AISI 1050	
	Screw Hole	M12	M16		M20		
Vibration	Grade A						
Balance	Half key method						
Shaft Key	Closed keyway						
Rating Plate	Material	Aluminium plate; 0,5 mm					
Earthing	One inside the terminal box and one on the frame next to the foot						
Protection Degree	IP 55 as standard, higher protection on request						
Cooling Method	Totally enclosed, fan cooled - IC 411						
Fan	Material	Polyethylene	Polypropylene				
Fan Cover	Material	Steel					
Drain Holes	Material	PA 6					

COMPONENTS:

132 - 250 ALUMINIUM FRAME

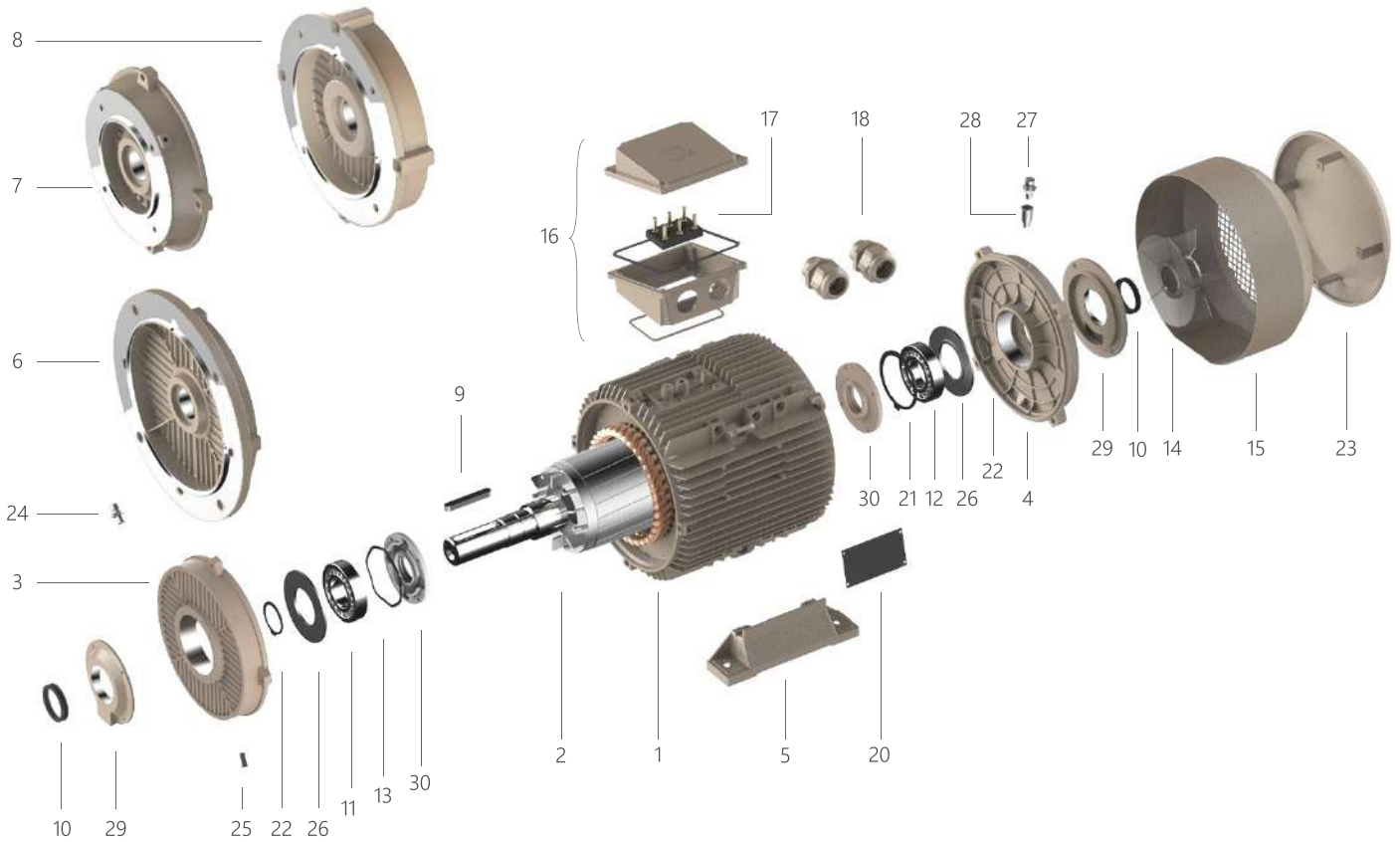

STANDARD DESIGN MOTORS

132 - 225 Frame Sizes

- 1 Frame and complete stator
- 2 Rotor with shaft
- 3 End shield, DE side
- 4 End shield, NDE side
- 5 Feet
- 6 B5 Flange
- 7 B14 Flange (for frame sizes 132 and 160)
- 8 B14 2nd Flange (for frame size 132)
- 9 Shaft key
- 10 V-Ring
- 11 Bearing, DE side
- 12 Bearing, NDE side
- 13 Wave spring
- 14 Fan
- 15 Fan cover
- 16 Terminal box
- 17 Terminal
- 18 Cable glands
- 20 Rating plate
- 21 Internal circlip (NDE side)
- 22 External circlip
- 23 Canopy
- 24 Vibration measurement nipple
- 25 Plug for drain hole

MOTORS with GREASING NIPPLES

160 to 250 Frame Sizes

- 1 Frame and complete stator
- 2 Rotor with shaft
- 3 End shield, DE side
- 4 End shield, NDE side
- 5 Feet
- 6 B5 Flange
- 9 Shaft key
- 10 V-Ring
- 11 Bearing, DE side
- 12 Bearing, NDE side
- 13 Wave spring
- 14 Fan
- 15 Fan cover
- 16 Terminal box
- 17 Terminal
- 18 Cable glands
- 20 Rating plate
- 22 External circlip
- 23 Canopy
- 24 Vibration measurement nipple
- 25 Plug for drain hole
- 26 Grease retaining disc
- 27 Grease nipple
- 28 Extension part for greasing nipple
- 29 Outer bearing cover
- 30 Inner bearing cover

MOTORS IN BRIEF: IE3 & IE4 MOTORS

160 - 400 CAST IRON FRAME

Frame Size		160	180	200	225	250	280	315	355	400	
Frame		Cast iron GG 20									
End shields	Material	Cast iron GG 20									
Flange (B5)	Material	Cast iron GG 20									
Flange (B14)	Material	Cast iron GG 20	—								
Feet		Integrated cast iron feet									
Painting	Material	Epoxy based, RAL 1019									
	Corrosion Class	C3, ISO 12944-2:2017									
Bearings	Locking	Locked at NDE with circlip				Locked at DE with bearing cover					
	Spring	DE Side				NDE Side					
	DE Side	2 pole	6309 ZZ C3	6310 ZZ C3	6312 ZZ C3	6313 ZZ C3	6315 C3	6316 C3	6316 C3	6317 C3	6317 C3
		4-8 pole							6319 C3	6322 C3	6324 C3
	NDE Side	2 pole	6209 ZZ C3	6210 ZZ C3	6212 ZZ C3	6213 ZZ C3	6315 C3	6316 C3	6316 C3	6317 C3	6317 C3
		4-8 pole							6319 C3	6322 C3	6324 C3
Seal	V-ring on both DE and NDE sides										
Lubrication	Grease	Permanently lubricated shielded bearings				Mobil Polyrex EM					
	Relubrication	M8 x 1 greasing nipples on request				M8 x 1 greasing nipples as standard					
Vibration Measurement Nipples	On Request	SPM									
Terminal Box	Material	Pressure die-cast aluminium alloy									
	Position	Top as standard									
Cable Connections	Cable Glands	2 x M40		2 x M50		2 x M63					
	Terminal	6 terminals for connection with cable lugs (lugs not included)									
Stator Winding	Material	Enameled copper wire									
	Insulation	Insulation class F, temperature rise B									
	Winding Protection	150°C FTC Thermistors, 1 set as standard									
Heating Elements	On Request	2 x 30W			2 x 40W			2 x 60W			
Rotor Winding	Material	Medium pressure die-cast, pure aluminium									
Shaft	Material	AISI 1040				AISI 1050		315M AISI 1050 315L AISI 4140		AISI 4140	
	Screw Hole	2 pole	M16		M20						M20
4-8 pole										M24	
Vibration		Grade A									
Balance		Half key method									
Shaft		Closed keyway									
Rating Label	Material	Aluminium plate; 0,5 mm									
Earthing		One inside the terminal box and one on the frame next to the foot									
Protection Degree		IP 55 as standard, higher protection on request									
Cooling Method		Totally enclosed, fan cooled - IC 411									
Fan	Material	Polypropylene									
Fan Cover	Material	Steel									
Drain Holes	Material	PA 6									

160 - 400 CAST IRON FRAME

COMPONENTS:

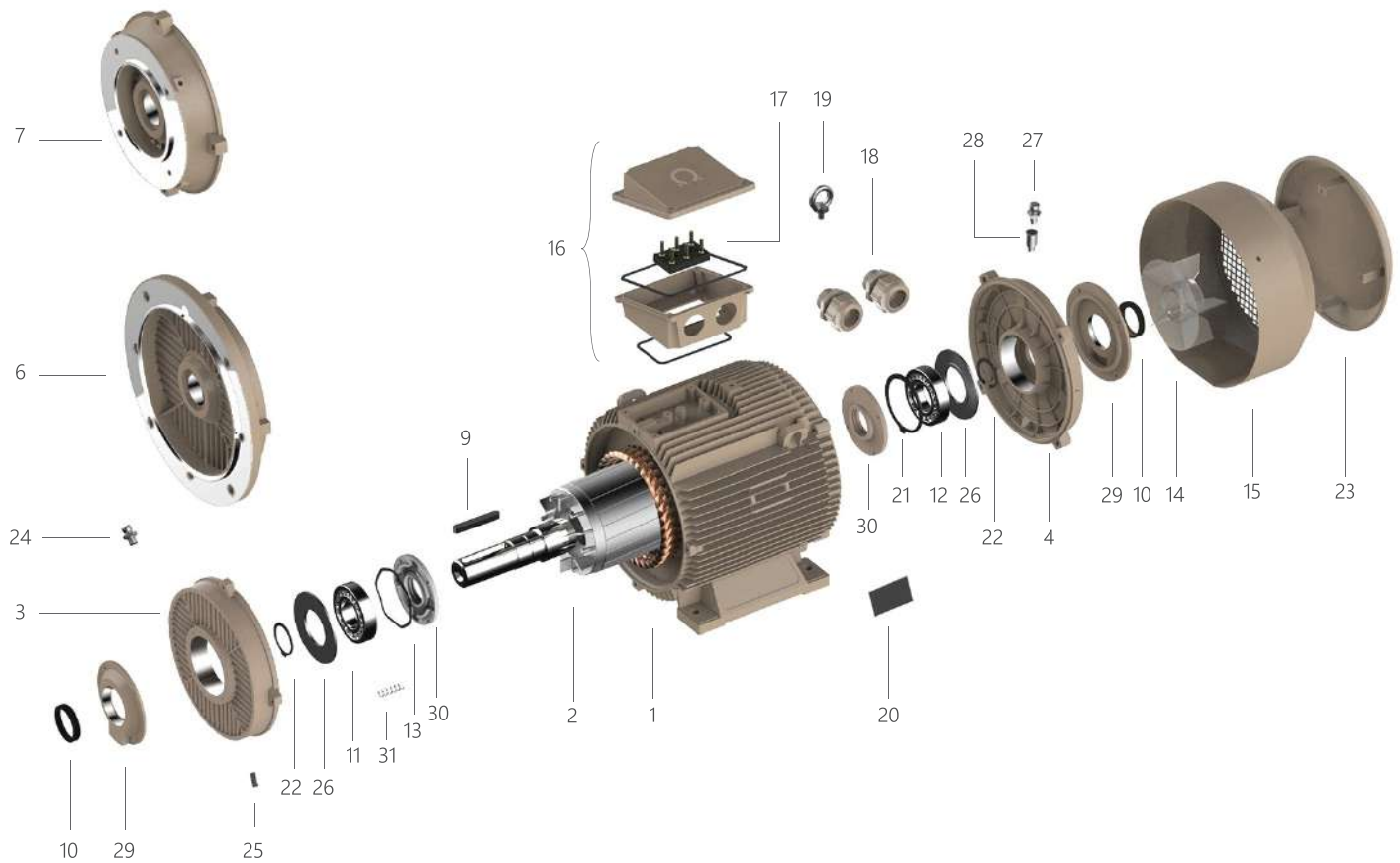

STANDARD DESIGN MOTORS

160 - 225 Frame Sizes

- 1 Frame and complete stator
- 2 Rotor with shaft
- 3 End shield, DE side
- 4 End shield, NDE side
- 6 B5 Flange
- 7 B14 Flange (for frame size 160)
- 9 Shaft key
- 10 V-Ring
- 11 Bearing, DE side
- 12 Bearing, NDE side
- 13 Wave spring
- 14 Fan
- 15 Fan cover
- 16 Terminal box
- 17 Terminal
- 18 Cable glands
- 19 Eyebolt
- 20 Rating plate
- 21 Internal circlip (NDE side)
- 22 External circlip
- 23 Canopy
- 24 Vibration measurement nipple
- 25 Plug for drain hole

MOTORS with GREASING NIPPLES

160 to 400 Frame Sizes

- 1 Frame and complete stator
- 2 Rotor with shaft
- 3 End shield, DE side
- 4 End shield, NDE side
- 6 B5 Flange
- 9 Shaft key
- 10 V-Ring
- 11 Bearing, DE side
- 12 Bearing, NDE side
- 13 Wave spring
- 14 Fan
- 15 Fan cover
- 16 Terminal box
- 17 Terminal
- 18 Cable glands
- 19 Eyebolt
- 20 Rating plate
- 22 External circlip
- 23 Canopy
- 24 Vibration measurement nipple
- 25 Plug for drain hole
- 26 Grease retaining disc
- 27 Grease nipple
- 28 Extension part for greasing nipple
- 29 Outer bearing cover
- 30 Inner bearing cover
- 31 Helical spring (for frame sizes 315 and 355)

Hakkımızda



İnovasyon



Sürdürülebilirlik



Sosyal Sorumluluk



Temel Değerlerimiz



Notlar

A series of horizontal lines for writing, with a large, faint watermark logo in the center. The logo consists of a large circle with a smaller circle inside it, and two triangles at the bottom corners.

Notlar

A series of horizontal lines for writing notes, with a large, faint watermark logo in the center.



Adress: Dudullu Organize Sanayi Bölgesi 2. Cadde No:10 Ümraniye - İstanbul

Telephone: +90 216 266 32 80

Fax: +90 216 266 32 99

E-mail: info@omegamotor.com.tr